



JK 1.25" Body Lift Kit

www.teraflex.com

Kit #4152100



Important Notes:

Prior to beginning this or any installation read these instructions to familiarize yourself with the required steps and evaluate if you are experienced and capable to personally perform these modifications. A factory service manual should be used in conjunction with these installation instructions.

Refer to the parts list to ensure that all necessary components and hardware has been included. If any parts are missing please contact your local TeraFlex dealer for assistance.

Note: Jeeps with a manual transmission will require the shift boot to be trimmed or have a shifter extension installed. Jeeps with an automatic transmission will not require any modifications.

Tools needed:

- This installation guide
- Floor Jack
- Wood Blocks (2x4, 4x4 etc.)
- Ratchet or Impact Wrench
- 18 mm Socket
- 21 mm Socket

YouTube

Scan to
watch the
video!



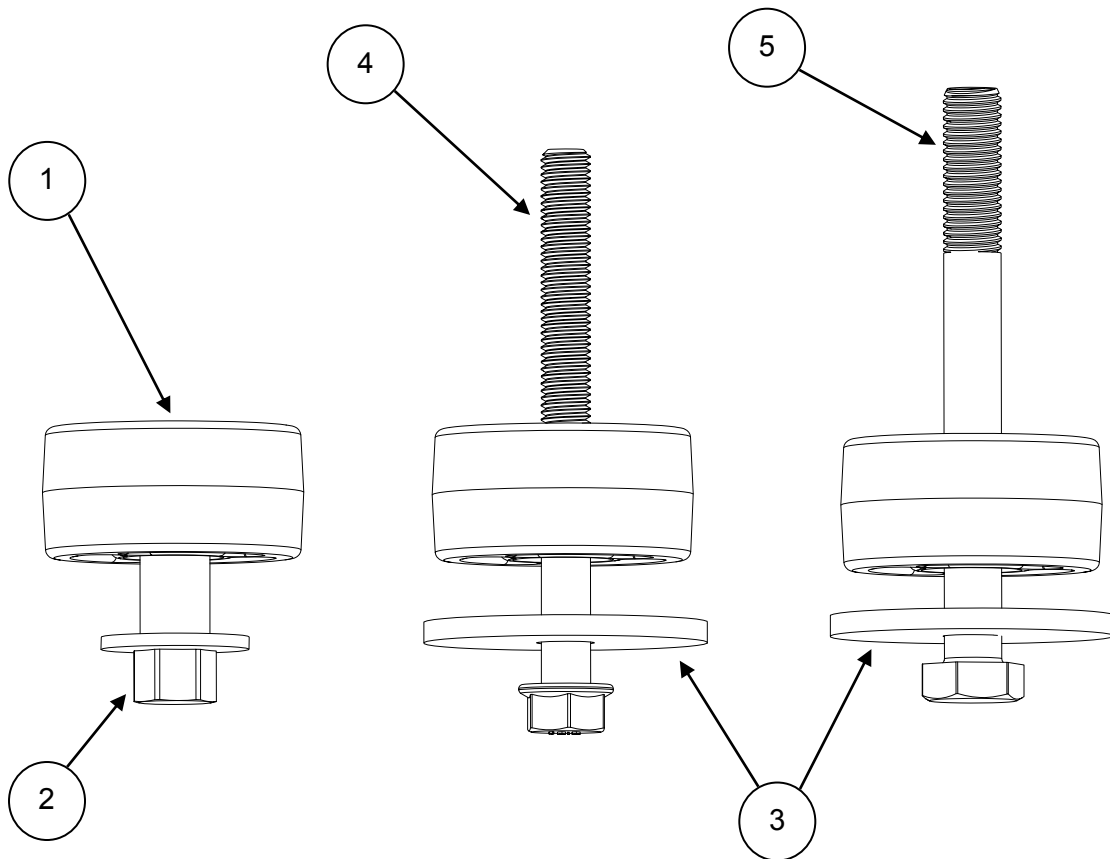

www.teraflex.com

Parts List – Kit #4152100

Item Number	Part Number	Description	Quantity
1	152102	Spacer JK Body Lift 1.25" Tall .75" Diameter Hole	12
2	152103	Nut M12 x 1.75 Custom for JK Body Lift	2
3	152104	Washer 14mm x 69mm O.D. Custom for JK Body Lift	10
4	243	Bolt M12 x 1.75 x 130mm Grd 10.9 Hex Zink JK Body Lift	10
5	244	Bolt M14 x 2.0 x 140mm Grd 10.9 Hex Zinc JK Body Lift	2

Park the vehicle on a flat level surface. Apply the parking brake and block the tires.

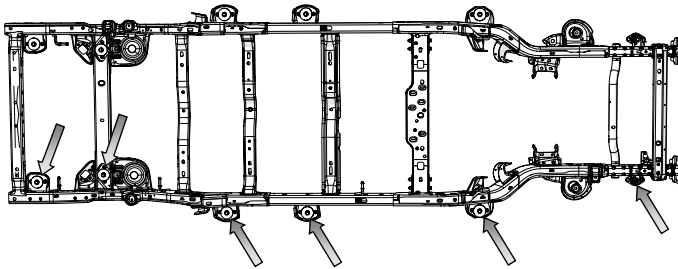
Note: 2 door JKs have 10 body mounts while 4 door JKs have 12. Hardware has been provided for both.



1 →
Front of Jeep

With an 18mm **loosen**, but **do not remove**, all body mount bolts/nuts on the **left side** of the Jeep, including the forward-most body mount nut.

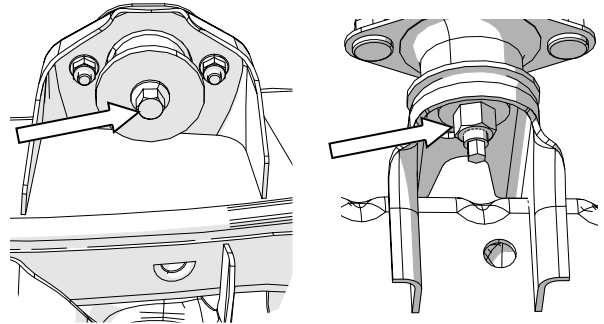

2 Body Mount Bolt Front-most Body Mount Nut

Remove all body mount bolts/nuts on the **right side** of the Jeep, including forward-most body mount nut.
NOTE: The rear-most body mounts on 2008-15 JKs use larger 14MM bolts. Two new 14MM bolts are supplied with the kit. 2007 models use 12MM bolts in the rear mounts.

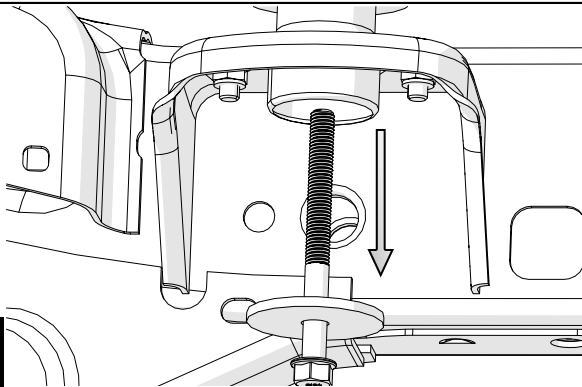

3

Place a floor jack under the right side of the body with the lift plate below the section of body just outboard of the frame, as shown. Place a block (2x4 or a 4x4) on the jack to distribute the load of the body.

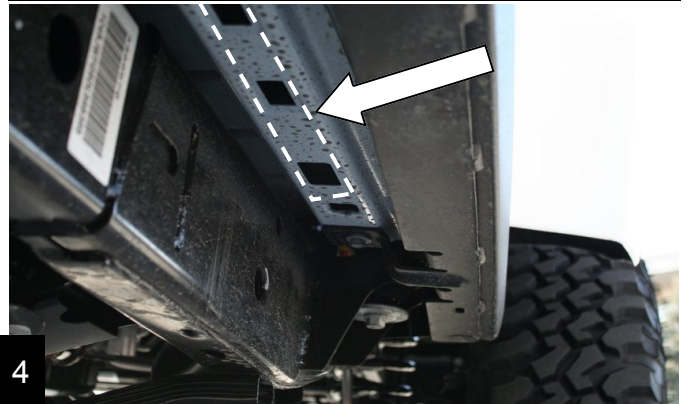

4

Raise the right side of the jeep body enough to insert the TeraFlex body lift spacers between the body and the factory mounts. It may be necessary to re-position the jack along the body as you progress from the front of the vehicle to the rear. **You will need to raise the body enough to fit a spacer between the stud of the forward-most mount and the frame.**

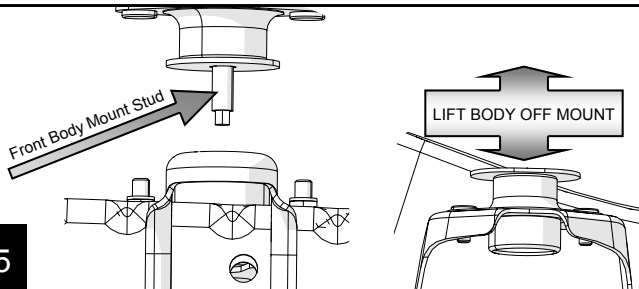

5

Slide the TeraFlex spacers into place.

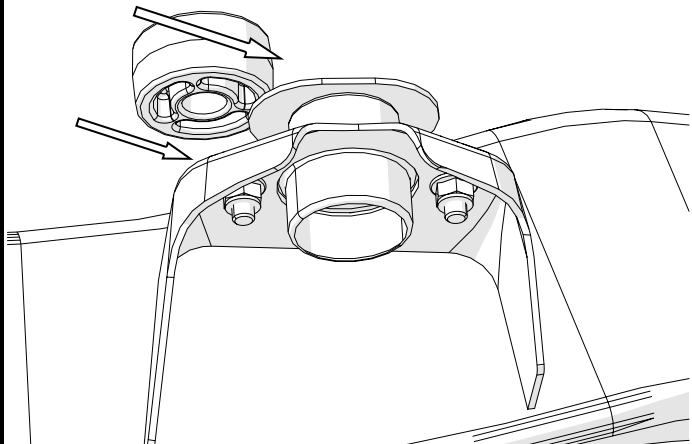

Lower the right side of the vehicle body down far enough to thread the supplied bolts into the body mount holes.

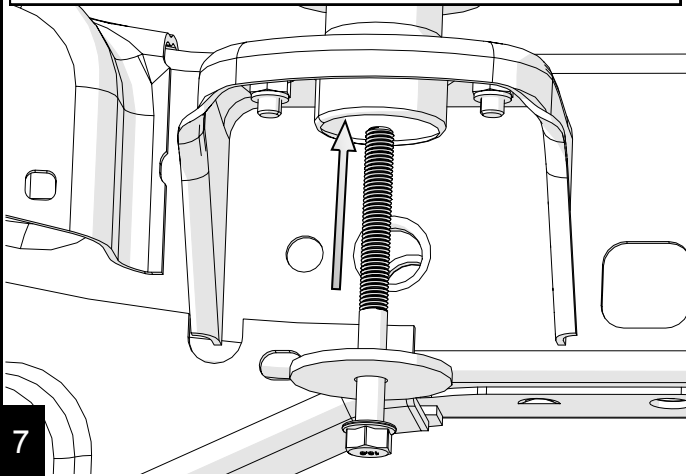

7

Loosely thread the new bolts with washers supplied in the kit through the body mounts and into the body of the Jeep.

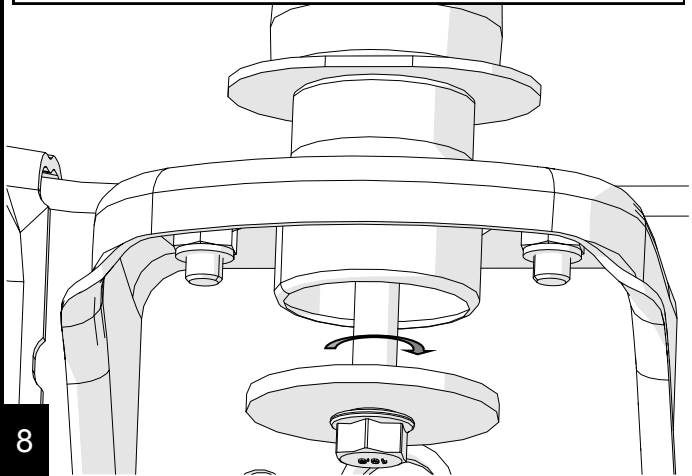

8

On the front right mount, **loosely thread** one of the supplied custom nuts onto the stud in the center of the body mount hole.

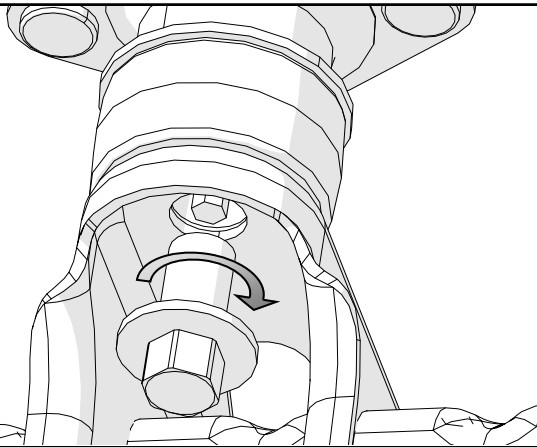

9

Lower the right side of the vehicle body completely onto the new body mounts.

Do not tighten right side body mount hardware yet.

10

Repeat steps 3 to 10 for the left side. Upon lowering left side of vehicle onto the new body mounts, torque all body mount bolts and the 2 front custom nuts.

Torque bolts to 80 ft-lbs

Torque custom nuts to 75 ft-lbs

11

After approximately 100 to 200 miles of driving re-torque bolts and nuts.

12



JK 1.25" Body Lift Kit

www.teraflex.com

PRODUCT INFORMATION

MAINTENANCE INFORMATION:

It is the buyer's responsibility to have all suspension, drivetrain, steering, and other components checked for proper tightness and torque after the first 100 miles and every 3000 miles after that.

NOTICE TO INSTALLER:

The enclosed "Warning to Driver" sticker must be installed in the vehicle in driver's view. This sticker is to act as a constant safety reminder when operating the vehicle. It is your responsibility as the equipment installer to install the provided sticker and to forward the product instructions to the vehicle's owner for review. If a "Warning to Driver" sticker or product installation guide were not included in the kit, FREE replacement stickers and instructions are available by request. It is the installer's duty to ensure a safe and controllable vehicle after the modifications have been performed.

WARNING:

Neither the seller nor the manufacturer will be liable for any loss, damage, or injury directly or indirectly arising from the use of or inability to determine the use of these products. Before using, the user shall determine the suitability of the products for its intended use, and the user shall assume all responsibility and risk in connection therewith.

WARNING TO DRIVER:

This vehicle has been modified to enhance off road performance and has unique handling characteristics. Use in harsh environments can cause extreme stress on the components. Vehicle should be inspected after being off road to make sure that all the components are in working order and safe to travel on the highway. All fasteners should be checked so that they are at the correct torque specifications as the vibration and stresses from off roading may cause critical fasteners to work loose. Extra care should be taken to inspect the critical components, steering, and brake systems. During each oil change components such as arms, tie rod ends, etc. should be greased and checked for excessive wear. Any worn components should be replaced. When returning to the pavement always set or restore tire air pressure to the factory recommendation and connect or engage any disabled sway bar mechanisms. Because of the higher center of gravity and larger tires, this vehicle handles and reacts differently than many passenger cars, both on and off road. You must drive it safely! Extreme care should be taken to prevent vehicle rollover or loss of control, which can result in serious injury or death. Avoid sudden sharp turns or abrupt maneuvers. Generally, braking performance and capabilities are decreased when significantly larger/heavier tires are used, especially when used in combination with transfer case low-range reduction kits. Take this into consideration while driving. Do not add, alter or fabricate any factory or aftermarket parts to increase vehicle height over the intended height of the TeraFlex product purchased. Mixing component brand is not recommended. TeraFlex Inc. will not be responsible for any altered product or any improper installation or use of our products. We will be happy to answer any questions concerning the design, function, and correct use of our products. It is ultimately the buyer's responsibility to have all bolts/nuts checked for tightness after the first 100 miles and then every 3000 miles. Wheel alignment, steering system, suspension and drive line systems must be inspected by a qualified professional mechanic at least every 3000 miles.

TERAFLEX PRODUCT WARRANTY:

TeraFlex Inc. warrants TeraFlex Suspension products to the original retail purchaser to be free of defects in material and workmanship for as long as the original purchaser owns the vehicle on which products were originally installed.

Failure to complete regular maintenance (grease every 3000 miles) on TeraFlex FlexArms will void this warranty. All other conditions of the standard TeraFlex product warranty apply.

All TeraLow products are covered by the TeraFlex two (2) year warranty to be free of defects in material and workmanship for two years from date purchased.

TeraFlex axles are covered by a 12-month warranty to be free of defects in materials and workmanship.

This warranty does not cover or include product finish, improperly installed or applied products, improperly maintained products, products or components used for racing or competition or damage due to abuse or neglect, products that fail due to the use of larger tire and wheel combinations.

All returns must be accompanied by an original invoice. It is the customer's responsibility to remove the product from the vehicle. Shipping charges are the responsibility of the customer. TeraFlex Inc. will pay the return freight if the product meets the terms of warranty.

This warranty is for the replacement or repair of defective TeraFlex products only and does not include freight charges, labor charges for removal of or installation of TeraFlex or related products or components, costs incurred due to down time of the vehicle, or lost profits due to vehicle down time.

A returned goods authorization number (RGA#) must accompany any returned products. For more information please contact a TeraFlex customer service representative.

COPYRIGHT

©Copyright 2014. All rights reserved, TeraFlex Inc. Reproduction of this catalog and/or any of its contents without written permission is strictly prohibited.

TeraFlex® is a registered trademark of TeraFlex Inc. All trade names and logos including but not limited to TeraFlex, FlexArms, RockGuard, Monster, and LCG are protected by law and duplication of trade names and/or logos are strictly prohibited.

TeraFlex Inc. reserves the right to update, discontinue, redesign, modify finish, part number or component build parts if deemed necessary without written notice.

TeraFlex Inc., and any associated dealers are not responsible for misprints or typographical errors that may have inadvertently been made within this instruction sheet.

Jeep® and the Jeep® grill are registered trademarks of Fiat Chrysler Automobiles N.V., and have no affiliation with TeraFlex Inc.