



OMIX-ADA, Inc.

460 HORIZON DR. SUITE 100 | SUWANEE, GA 30024 | PHONE: 770-614-6101 | FAX: 770-614-6069 | info@omix-ada.com

Part 11640.30

## TJ Hurricane Fender Flares

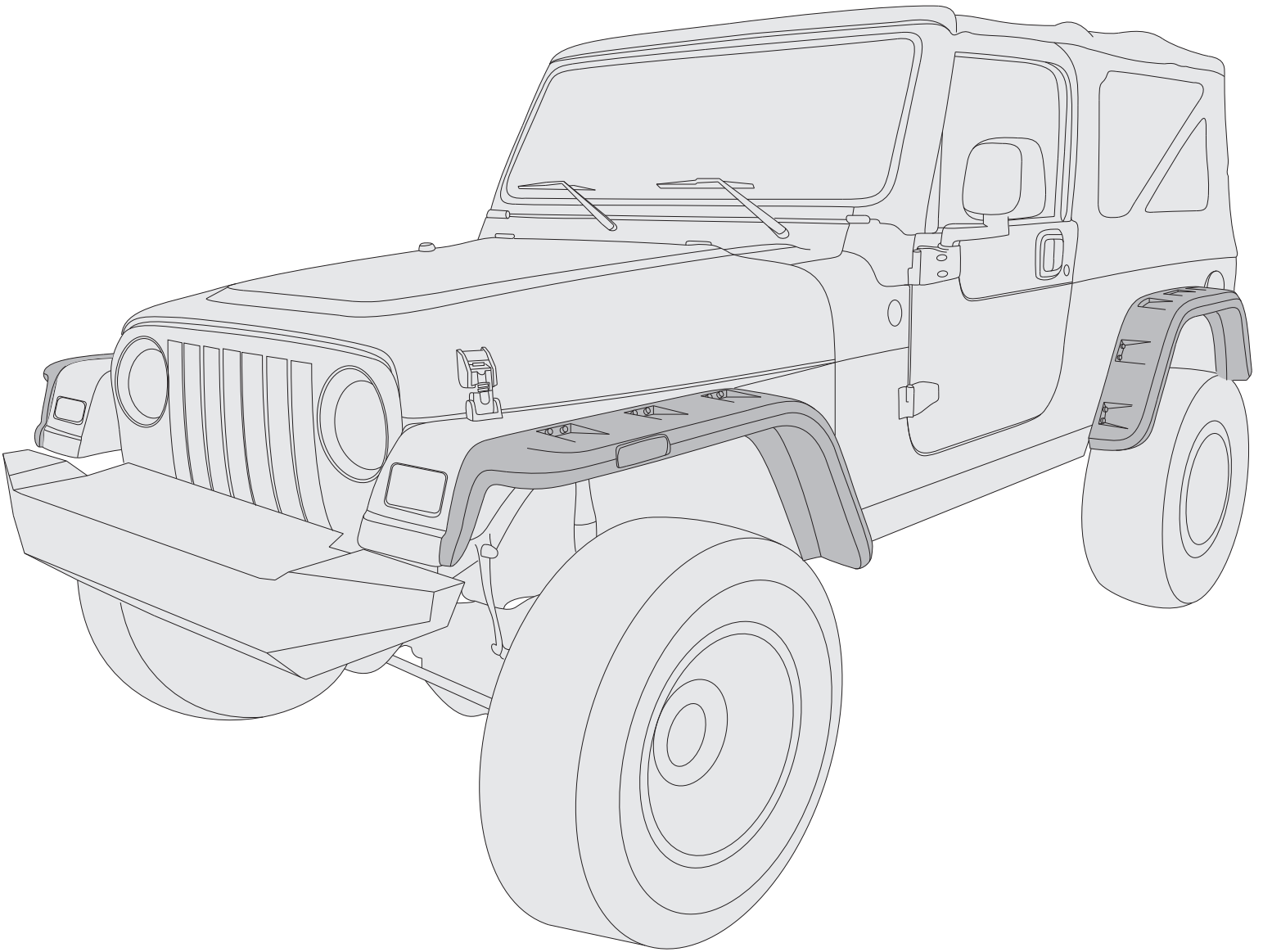



OMIX-ADA, Inc.

460 HORIZON DR. SUITE 100 | SUWANEE, GA 30024 | PHONE: 770-614-6101 | FAX: 770-614-6069 | info@omix-ada.com

# TJ Hurricane Fender Flares

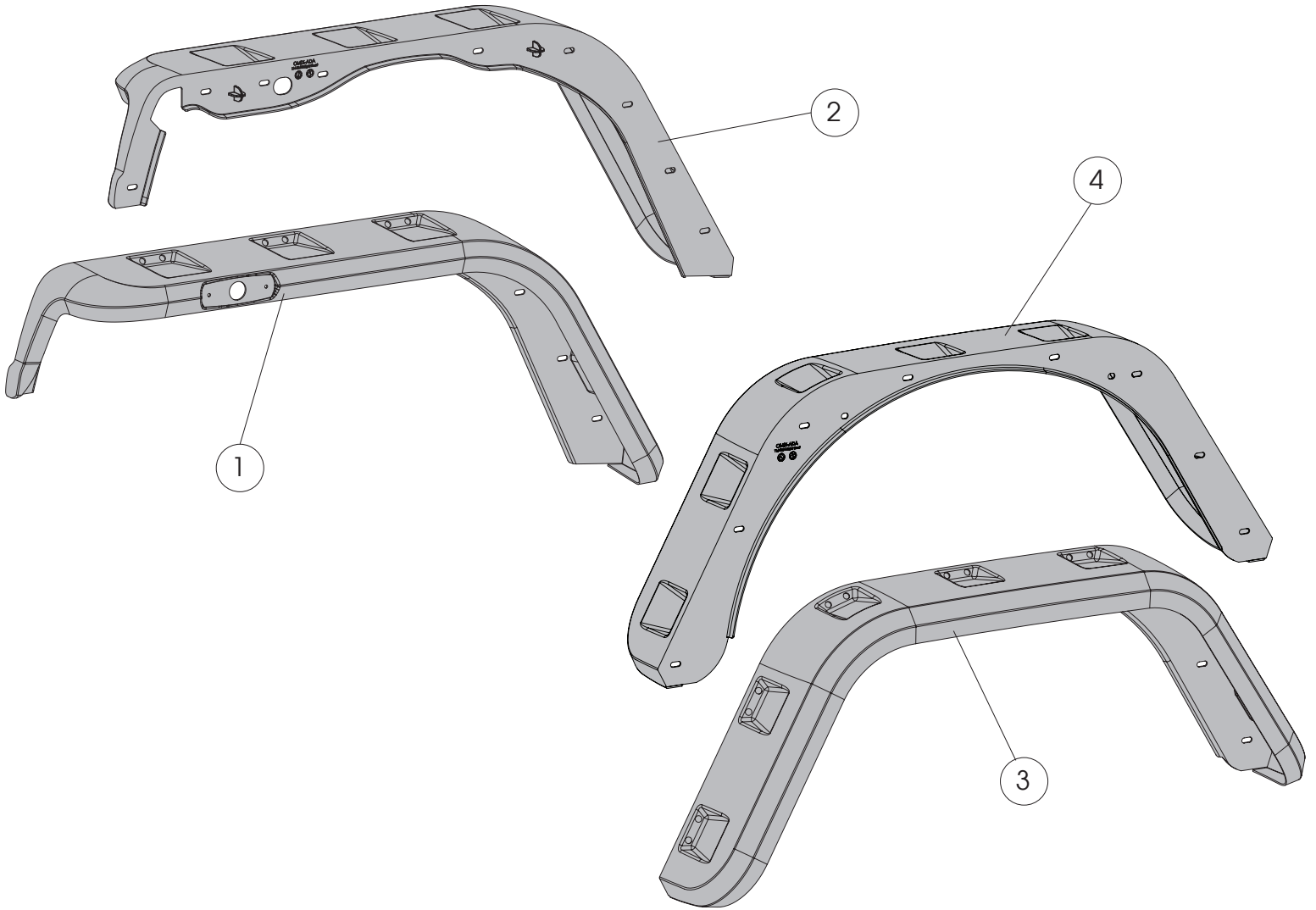

## Components

- 1. Front Flare, LH (1)
- 2. Front Flare, RH (1)
- 3. Rear Flare, LH (1)
- 4. Rear Flare, RH (1)

### OMIX-ADA® TECHNICAL SUPPORT

PHONE: M-F 8am - 5pm EST 1-800-449-6649 | EMAIL: techsupport@omix-ada.com

FOR WARRANTY INFORMATION VISIT: [www.Omix-Ada.com](http://www.Omix-Ada.com)



OMIX-ADA, Inc.

460 HORIZON DR. SUITE 100 | SUWANEE, GA 30024 | PHONE: 770-614-6101 | FAX: 770-614-6069 | info@omix-ada.com

# TJ Hurricane Fender Flares

## Hardware Components

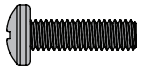

M4 Phillips Head Screw (4)



M4 Flange Nut (4)

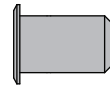

M5 Flanged Rivet Nut (12)

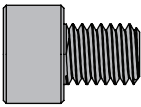

M8 Socket Cap Screw (56)

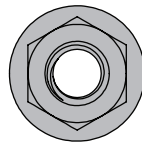

M8 Flange Nut (56)



Butt Connector (8)

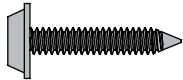

M3.9 Flange Head Self-Tapping Screw (22)

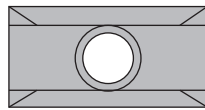

M3.9 Plastic T-Slot Nut (22)



Side Marker Housing (1)

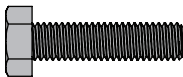

M5 Hex Bolt (12)



M5 Flat Washer (34)

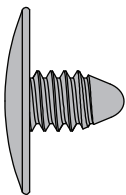

Shield Retainer (6)

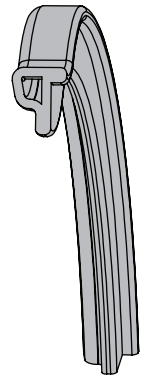

Edge Trim (1 Roll)

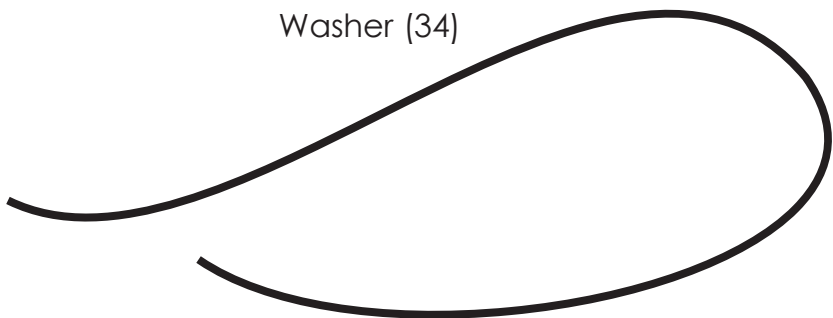

Black Wire Extension (2)

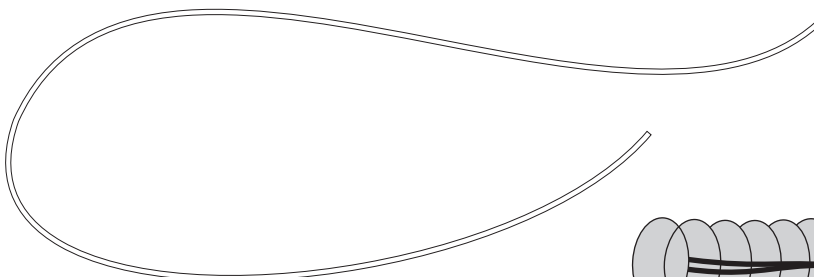

White Wire Extension (2)

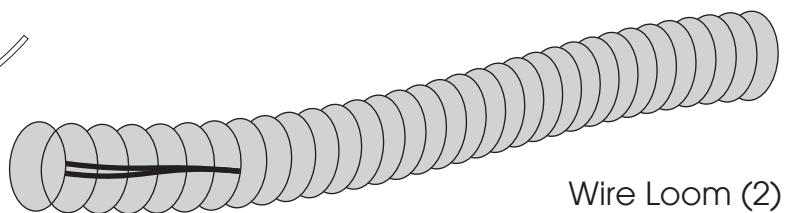

Wire Loom (2)



OMIX-ADA, Inc.

460 HORIZON DR. SUITE 100 | SUWANEE, GA 30024 | PHONE: 770-614-6101 | FAX: 770-614-6069 | info@omix-ada.com

# TJ Hurricane Fender Flares

- 1. Disconnect side marker lights, twisting bulb counter-clockwise.
- 2. Remove front flares, retaining all hardware.

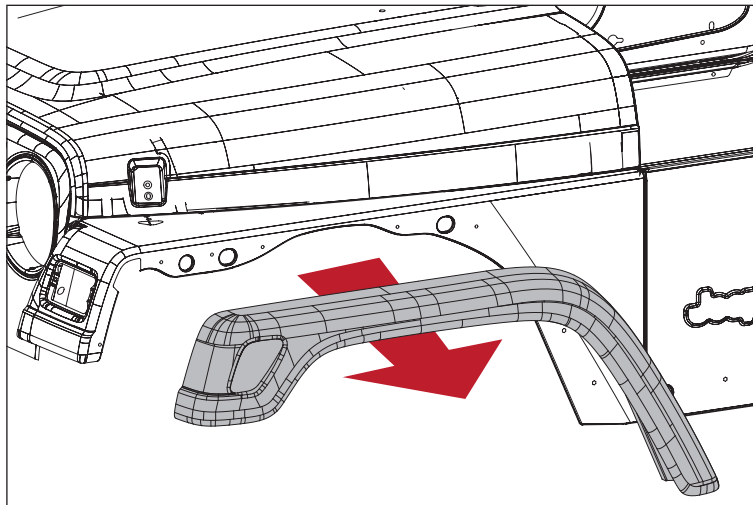

- 3. Remove rear flares and retain all hardware.

**NOTICE** Removing or pulling back rear fender liner is necessary for this step. Shield retainers may need to be removed.

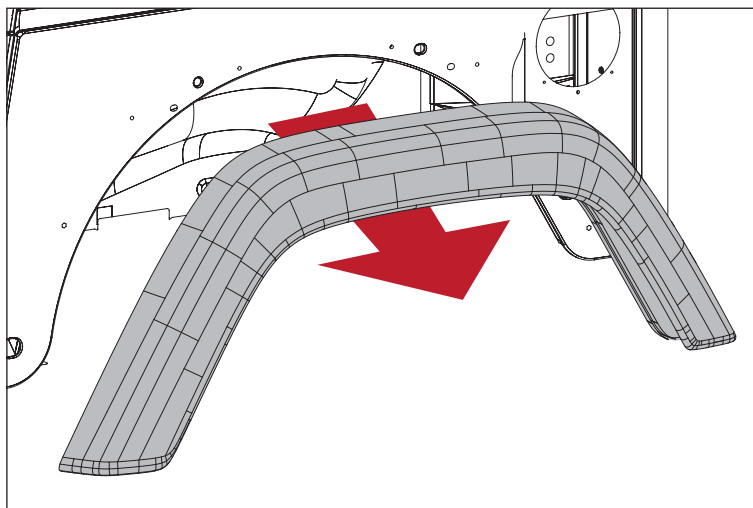

- 4. Clean body panels and body sides of flares before installation.

- 5. Begin to install front flares by first lining up placement pins with body panel holes.

- 6. Attach front flares using M3.9 Flange-Head Screw and T-slot Nut for front holes and M5 Hex Bolt, Washer, and Rivet (if needed) in rear holes. Do not fully tighten.

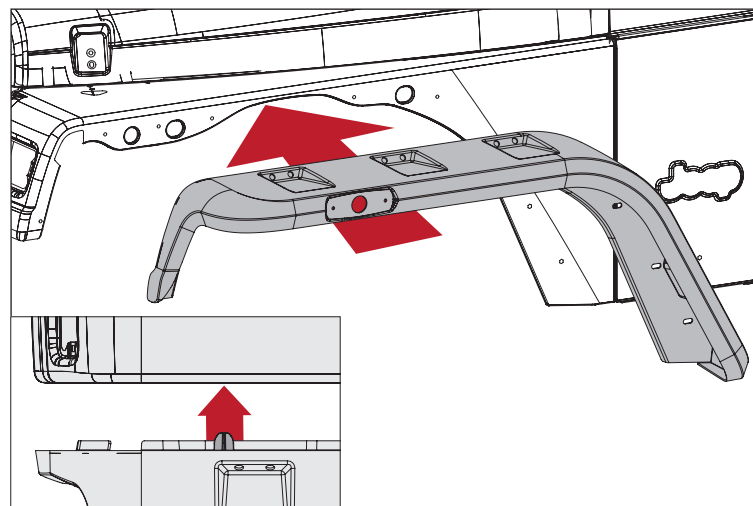



OMIX-ADA, Inc.

460 HORIZON DR. SUITE 100 | SUWANEE, GA 30024 | PHONE: 770-614-6101 | FAX: 770-614-6069 | info@omix-ada.com

## TJ Hurricane Fender Flares

7. Peel 2-3 inches of red tape covering back away from trim edge.

8. Starting with the front of the flare, begin to install Edge Trim to top edge of flare with adhesive side contacting inside edge of flare.

9. Gradually remove red tape covering while pressing remaining Edge Trim into place. Tighten bolts accordingly as trim is installed

**NOTICE** Do not stretch Edge Trim during application.

10. Trim excess Edge Trim from ends of each flare.

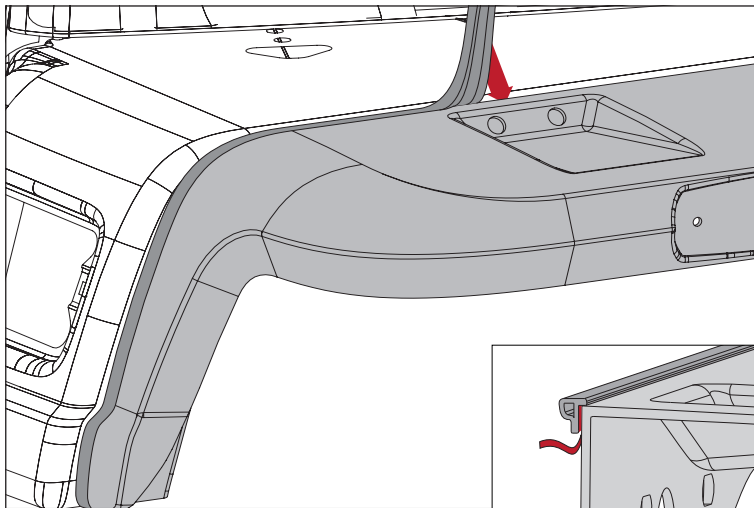

11. Loosely attach Rear Flares using M3.9 Flange-Head Screw and T-slot Nut for front holes and M5 Hex Bolt, Washer, and Rivet (if needed) in rear holes.

12. Repeat trim installation for rear flares.

**NOTICE** If any shield retainers were removed during installation, replace them now.

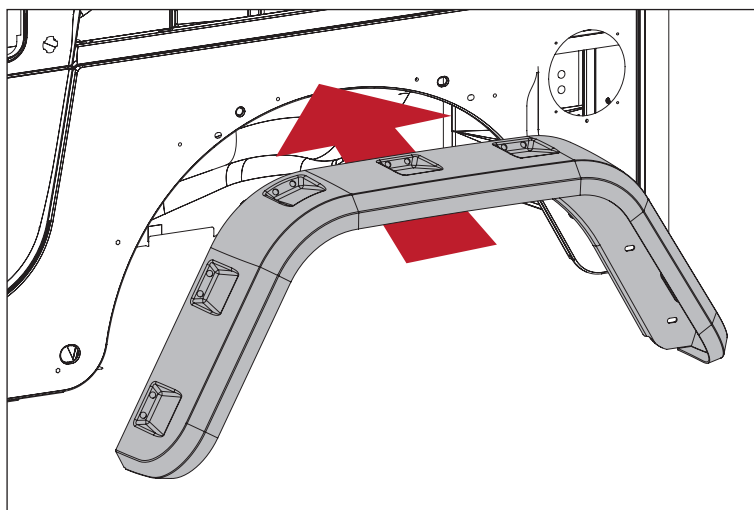

13. Install M8 Socket Cap Screws and Flange Nuts to side wall of pockets and tighten fully.

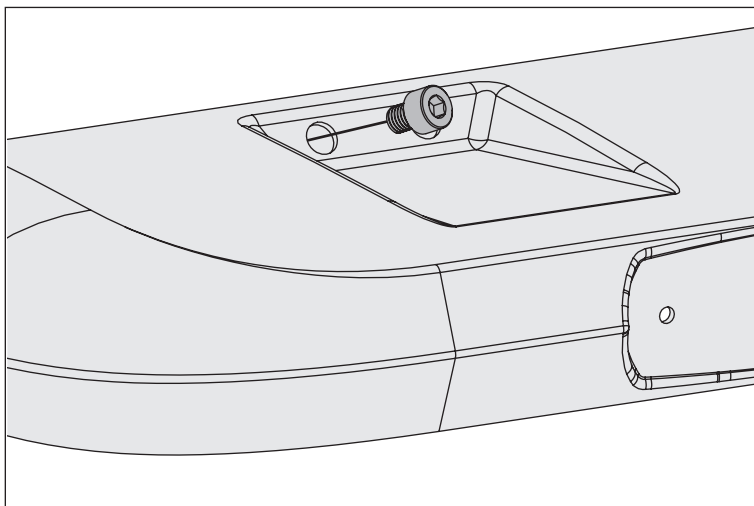



OMIX-ADA, Inc.

460 HORIZON DR. SUITE 100 | SUWANEE, GA 30024 | PHONE: 770-614-6101 | FAX: 770-614-6069 | info@omix-ada.com

## TJ Hurricane Fender Flares

14. Install Side Marker Housing using M4 Phillips Head Screw and Flange Nut. Tighten fully.

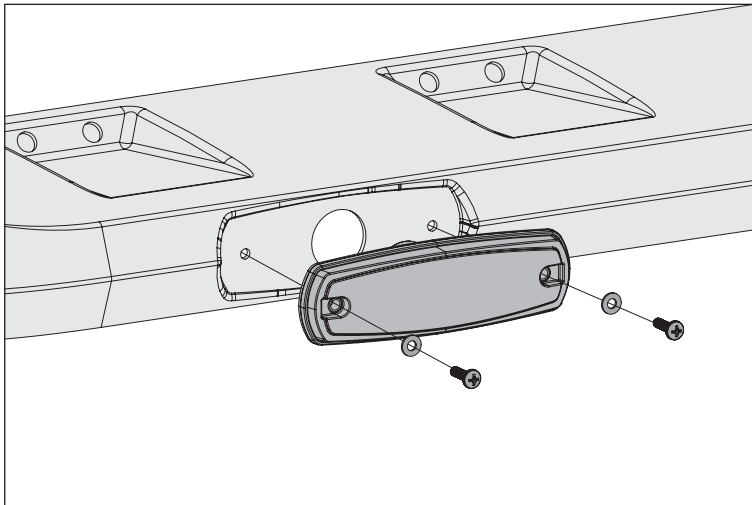

15. Cut bulb wire 2" from base of bulb fixture. Strip 1/4" from the ends of each wire.

16. Splice bulb wires with supplied black and white Extension Wire and Butt Connectors.

17. Wrap exposed wire with Wire Loom.

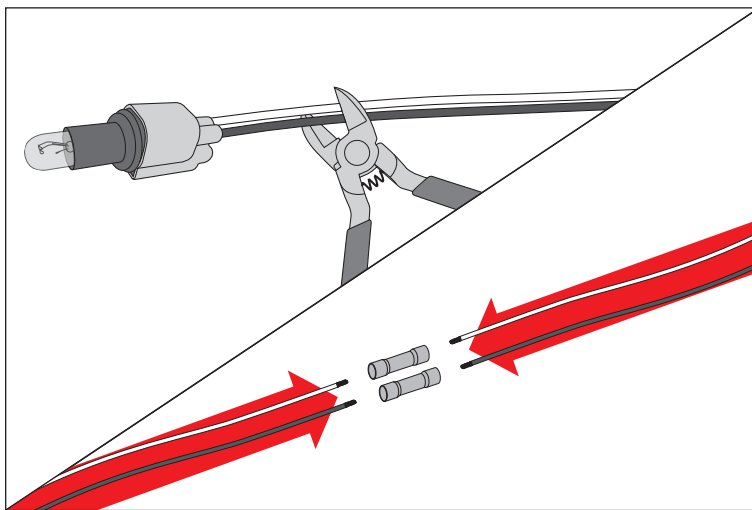

18. Reattach side marker bulb through large hole in fender to Side Marker Housing. Twist clockwise to secure.

