

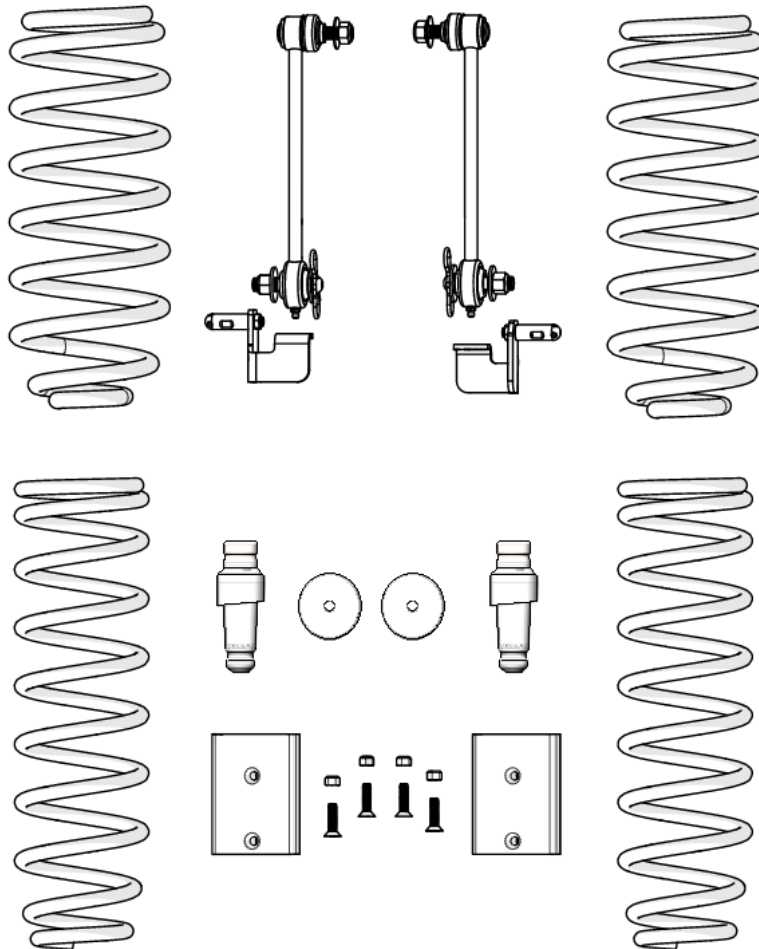

Sport S/T1 Suspension Installation Guide

www.teraflex.com

- | | |
|--|--|
| #1211033 JK 2-Door Sport S/T1 (w/ 3.3 Falcon Shocks) | #1311033 JK 4-Door Sport S/T1 (w/ 3.3 Falcon Shocks) |
| #1211032 JK 2-Door Sport S/T1 (w/ 3.2 Falcon Shocks) | #1311032 JK 4-Door Sport S/T1 (w/ 3.2 Falcon Shocks) |
| #1211031 JK 2-Door Sport S/T1 (w/ 3.1 Falcon Shocks) | #1311031 JK 4-Door Sport S/T1 (w/ 3.1 Falcon Shocks) |
| #1211021 JK 2-Door Sport S/T1 (w/ 2.1 Falcon Shocks) | #1311021 JK 4-Door Sport S/T1 (w/ 2.1 Falcon Shocks) |
| #1211000 JK 2-Door Sport S/T1 (No Shocks) | #1311000 JK 4-Door Sport S/T1 (No Shocks) |



Important Notes:

Prior to beginning this or any installation read these instructions to familiarize yourself with the required steps and evaluate if you are experienced and capable to personally perform these modifications. A factory service manual should be used in conjunction with these installation instructions.

Refer to the parts list to ensure that all necessary components and hardware has been included. If any parts are missing please contact your local TeraFlex dealer for assistance.

1211033 JK 2-Door Sport S/T 1

PART NO.	DESCRIPTION	QTY.
467125	Bumpstop RAW JK Front Speedbump 1.25" Tall x 3.5" OD Extruded UHMW	2
600057	Hardware Pack for JK Leveling Kits	
600093	Hardware JK Quick Disconnect HRWQDJK TC 4400NB2	1
610070	Hardware Pack Bumpstop Pads (F 1.25", R 0.75")	1
753006	JK 0"-3" Front Quick Disconnect Swaybar Link w/ Upper Swivel Stud	2
954600	JK Rear Lower 3/4" Tall Bumpstop Spacer	2
998000	Subassembly, Pressed, JK Front Upper Foam Bumpstop & Extension	2
1853020	JK 2 Door 1.5" Front Spring (Single)	2
1854020	JK 2 Door 1.5" Rear Spring (Single)	2

1312000 JK 4-Door Sport S/T 1

PART NO.	DESCRIPTION	QTY.
467125	Bumpstop RAW JK Front Speedbump 1.25" Tall x 3.5" OD Extruded UHMW	2
600057	Hardware Pack for JK Leveling Kits	
600093	Hardware JK Quick Disconnect HRWQDJK TC 4400NB2	1
610070	Hardware Pack Bumpstop Pads (F 1.25", R 0.75")	1
753006	JK 0"-3" Front Quick Disconnect Swaybar Link w/ Upper Swivel Stud	2
954600	JK Rear Lower 3/4" Tall Bumpstop Spacer	2
998000	Subassembly, Pressed, JK Front Upper Foam Bumpstop & Extension	2
1853050	JK 4 Door 1.5"/ 2 Door 2.5" Front Spring (Single)	2
1854050	JK 4 Door 1.5"/ 2 Door 2.5" Rear Spring (Single)	2

Tools Needed

- Ratchet - 1/4" and 1/2"
- 1/4" Drive Socket Set - 10mm
- 1/2" Drive Swivel/Wobbly Sockets - 18mm, 21mm, 3/4"
- 1/2" Drive Socket Set - 18mm, 21mm, 3/4"
- 1/2" Extension - 12" Long
- Hex Bit Socket or Allen Key - 3/16", 5mm
- End Wrench Set - 1/2", 15mm, 16mm, 18mm, 19mm, 21mm
- Drill
- Drill Bit Set - 1/8", 1/4", 3/8", 1/2" - or step drill bit
- Wire Cutters
- Locking Pliers
- Heel Pry Bar
- Hammer
- Chisel
- Measuring Tape
- Blue Loctite

Lift the vehicle and support it by the frame.
Remove wheels and support the front axle.
Loosen all of the control arms bolts (front and rear), but do not remove control arms or bolts.
Remove the exhaust skid plate/cross member using an 18mm.
The exhaust skid plate will not be reused.



1

Front Installation

Remove the front driveline at the axle and support it up out of the way with a bungee or strap (15mm).

Remove the track bar at the axle with a 21mm. The nut is a flag nut.

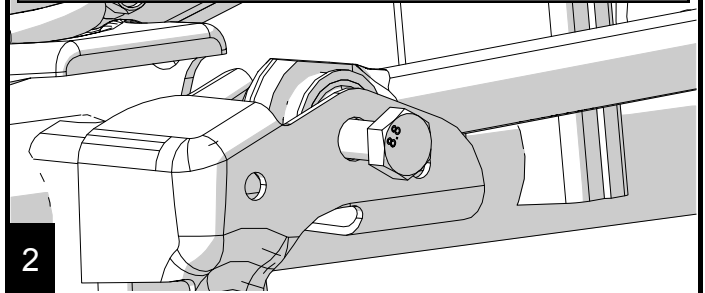

2

Remove front shocks. On 2012+ JK's, the passenger side upper shock mount is not accessible due to the battery tray. Use a pair of plyers and break out enough of the thin plastic to gain access to the 17mm nut.

Remove both swaybar links and retain the hardware.

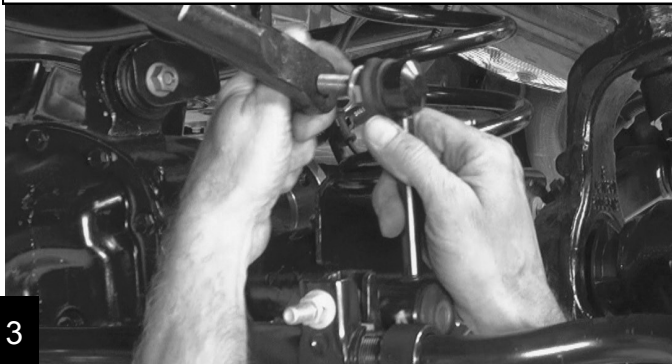

3

2011+ JK's have brake line retainers located under the spring perches. Use vise grips or a heel bar to spread the bracket enough to free the brake line. Use a 10mm to remove and discard the bracket.



4

Remove the bump stops from the upper spring buckets.

Unclip the ABS lines, and extend the breather tube by sliding the tube retainer clip down the shock tower 3". This will prevent the tube from being pulled tight during full axle droop.

Lower the axle and remove the front springs. Be sure to check for any lines that can be pulled or damaged.

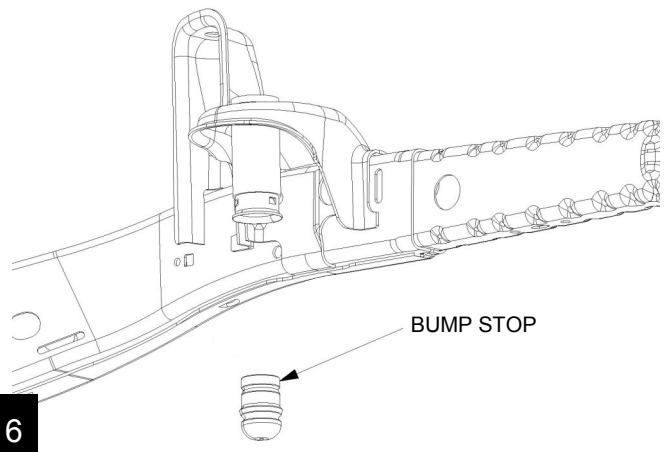

6

5

Drill Holes for Speedbump Pad

Locate the center of the front axle spring pads and drill a 3/8" [9.5mm] hole in the center of the pads. Speedbump pads will be installed along with the springs.

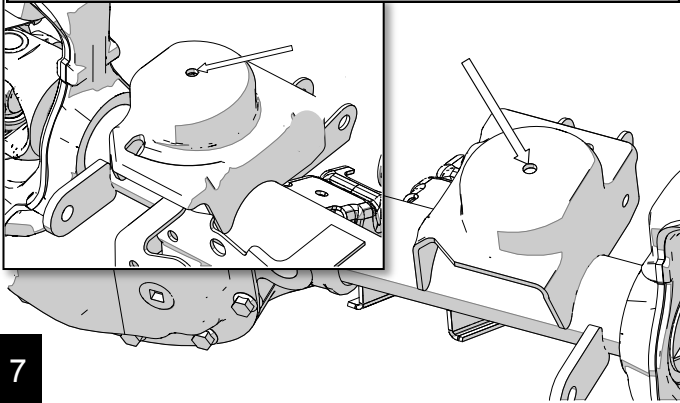

7

Install Extended Bumpstop

Install the Front Extended Bumpstop by aligning the factory jounce tube and bumpstop (marking on Cup Extension to be facing the front of the Jeep, see picture). Use a hydraulic jack and raise the axle until they are seated together.

Note: A block of wood between the axle and bumpstop may be necessary, as well as a small amount of silicone spray, to help install the bumpstops and extensions. Repeat process for the other side.

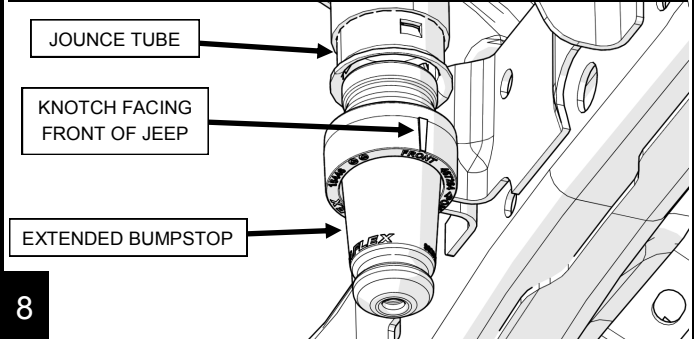

8

Install Front Springs and Speedbump Pads

Reinstall factory rubber spring isolator if it was removed. To help install the front Teraflex springs and Speedbump pads, install together onto the front axle coil spring pad. Install a bolt through the pads with the nut below the spring pads.

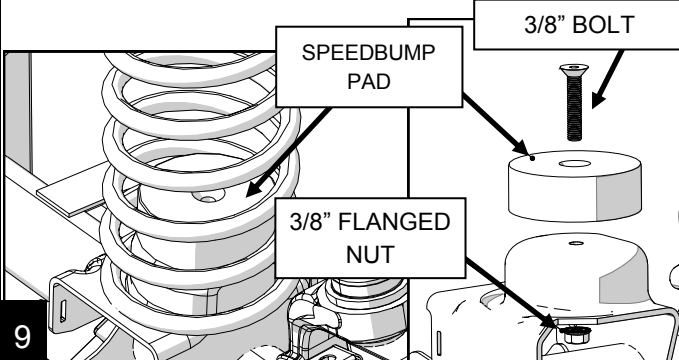

9

Front Shocks

If using Falcon Shocks follow instruction included with them to install the fronts now. If using other shocks install them now. Torque the top nut to 20 ft-lbs (27 N-m) and the bottom bolt to 56 ft. lbs. (76Nm)

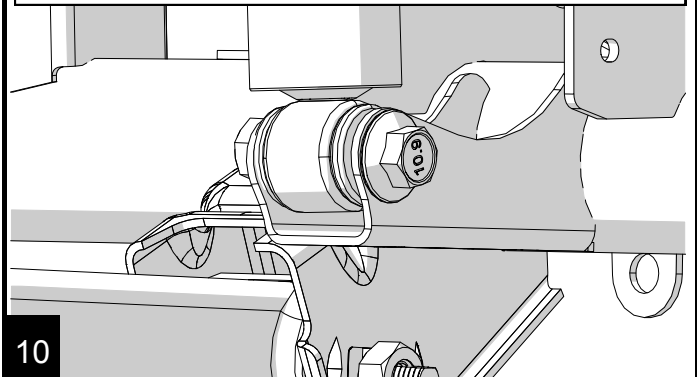

10

Install Front Sway Bar Quick Disconnects

Insert lower stud 600499 into axle bracket as shown. Place washer 37 and nylock nut 488 onto the lower stud. Note: The stud is stainless steel and the threads are soft. Take care to not over tighten the nut. **Torque to 59 ft-lbs.**

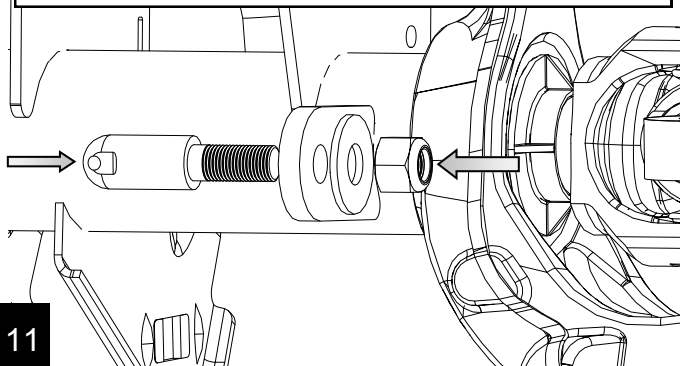

11

Insert the upper stud of the quick disconnect sway bar linkage into the factory sway bar. Place washer 477 and nylock nut 44 onto the stud.

Use a 6mm allen to hold the stud, tighten down the nut with a 18mm wrench.

Torque nylock nut to 59 ft-lbs.

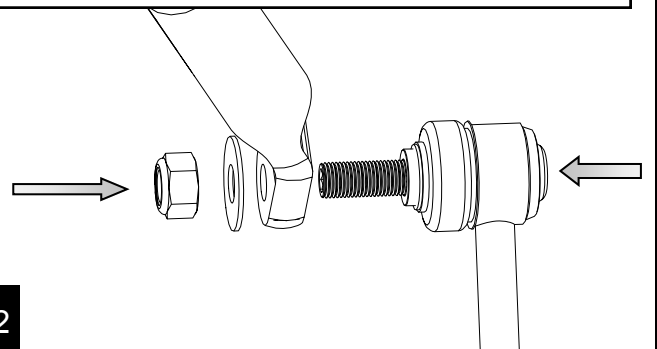

12

Slide the lower end of sway bar link onto the stud. Place washer 3801 on stud and insert Bow Tie Pin. Note: This should be a tight fit for better sway bar function. Applying a bit of grease to the stud and bushing will help with install.

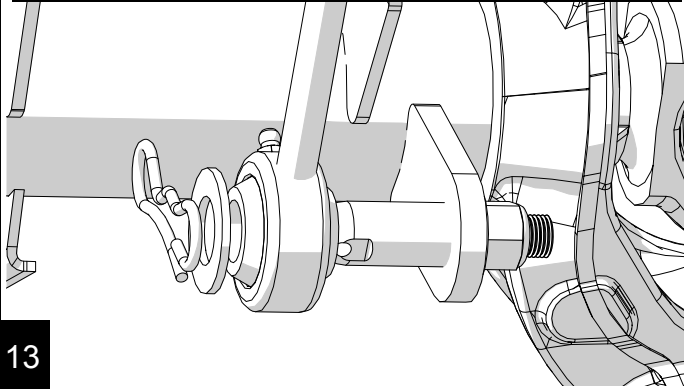

13

Remove the front body mount nut from the stud and slide on retaining bracket 600277. Reinstall the body nut. Next insert stud 600503 into retaining bracket and install jam nut 73.

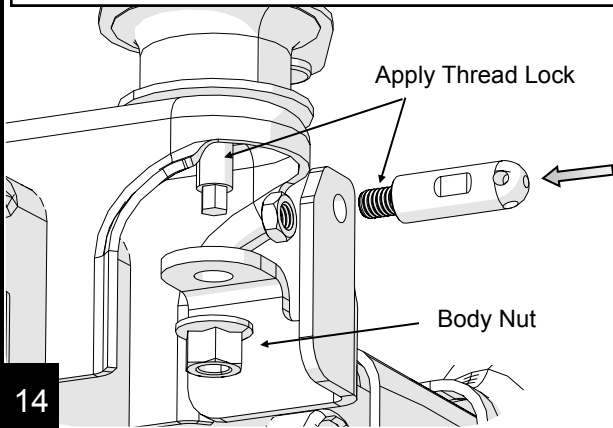

14

Torque the body mount to **80 ft-lb** and jam nut to **59 ft-lb**.

Repeat steps for the other side.

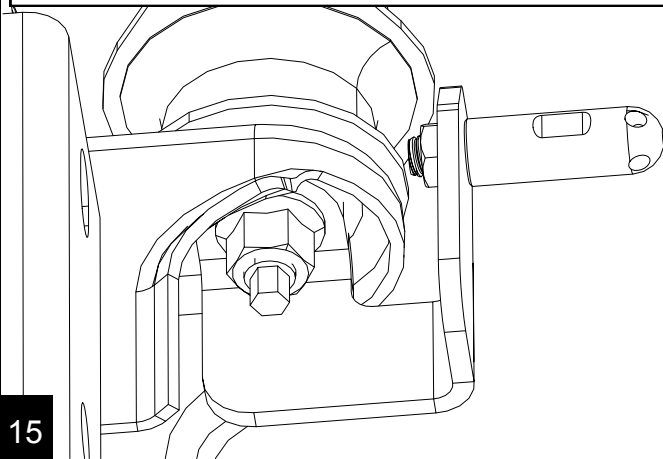

15

Rear Installation

Support the rear axle. Completely remove the rear shocks and axle side trackbar bolt.

Release the axle breather tube from the upper retaining clip on the underside of the Jeep body.

Release the ABS line from the two retaining clips on the axle (on each side).

Remove rear swaybar links.

16

Remove the brake line support brackets from the frame and lower the axle enough to remove the coil springs.

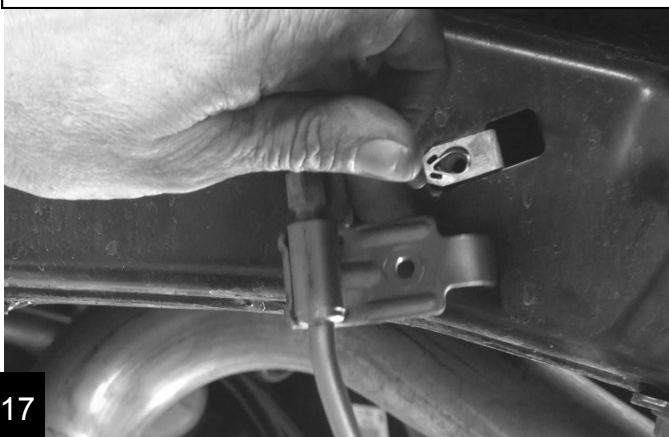

17

Fully remove the part brake cables from the hanger bracket and discard the bracket.

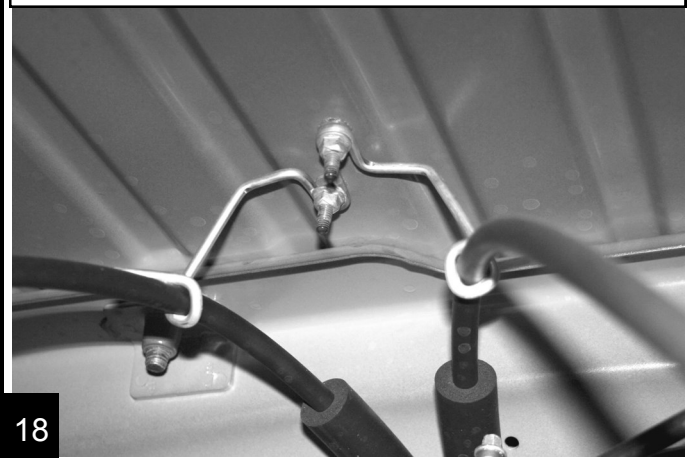

18

IMPORTANT NOTE! Due to clearance issues with the bumpstop pad on the axle it is important to have the frame side factory trackbar bolt installed from the front, and the nut to the rear.

Caution: For Jeeps that have our weld in Teraflex Rear Speedbumps, this step will not work. Instead, grind the end of the bolt flush with the nut so it clears the pad.

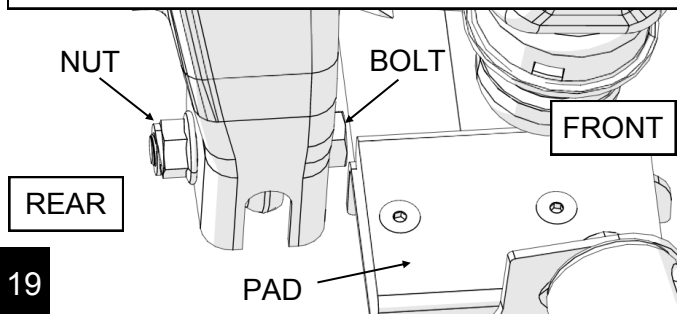

19

Install Front Swaybar Links in Place of Rear Links
Install the replaced front swaybar links in place of the rear links. The ball joint stud end on top and with the mounting stud pointing towards the frame.
Torque upper and lower to 59 ft-lbs.

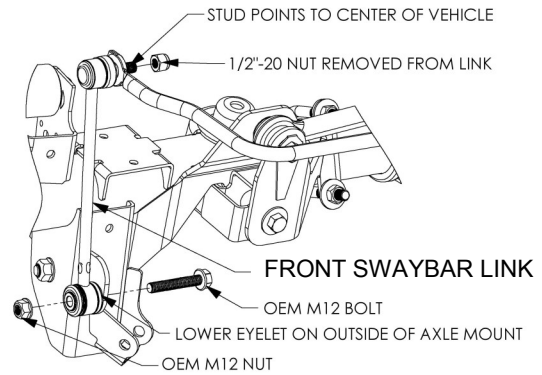

20

IMPORTANT NOTE! It is imperative at this time to cycle the swaybar and check for proper clearance between the swaybar and the brake line. Make the necessary bends in the brake line and bracket to clear the swaybar link as it goes through its range of travel.



21

Install Rear Springs

Install the factory rear upper spring isolators and the new rear coil springs. **Note:** The upper pigtail end needs to be all the way to the rear of the Jeep.

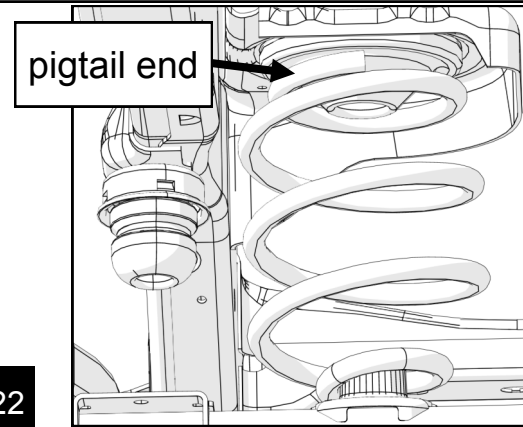

22

Rear Shocks

If your kit came with Falcon Shocks then install them now, following their instructions. If installing other shocks install them using the two upper bolts with a 16mm and the lower nut and bolt with an 18mm. Torque the upper bolts to 37 ft-lbs (50 Nm) and lower bolts to 56 ft-lbs (76 Nm).

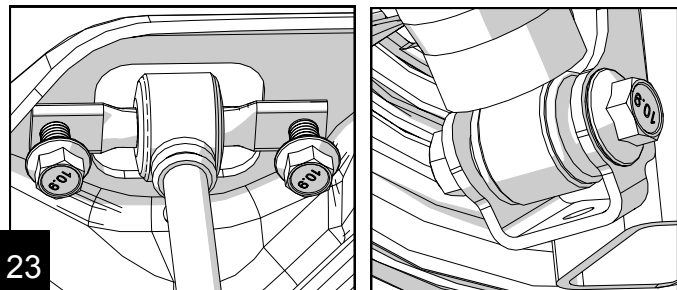

23

Install Rear Lower Bumpstop Pad

Locate the rear lower bumpstop kit (19454605) and install the lower bumpstop pad with the extended end facing forward. Torque to 200 in-lbs. (22 Nm).

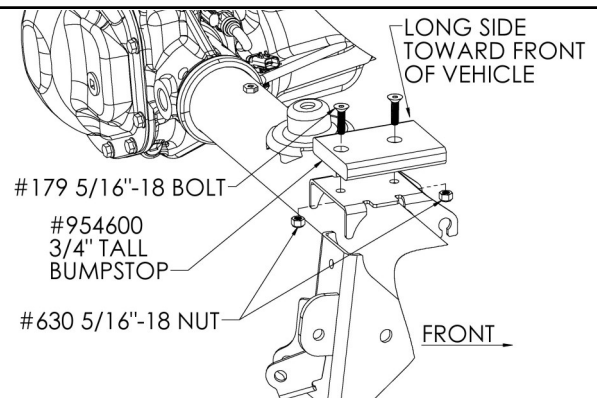

24

Secure the axle breather tube to the cross member.



25

EVAP Canister Relocation

Note: 2012+ 4-Door Wrangler must relocate the EVAP canister for proper driveline clearance at full suspension articulation. 2007-2011 4-Door and all 2-Door JK's skip to step 28.

Locate the EVAP canister and skid plate located under the vehicle next to the rear driveline. Use a 16mm to remove the two front bolts of the EVAP canister. Loosen, but do not remove the rear bolt.

Mark a centerline of the existing holes (labeled Centerline). Mark a spot about half way between the two existing holes (labeled Point 1) and one 50mm to the left of Point 1. (labeled Point 2). Center punch and drill a 1/2" hole at Points 1 and 2. Use a small block of wood as a spacer behind the bracket for drilling.

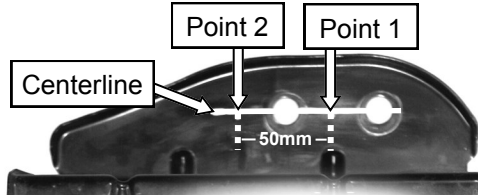

26

Results after drilling.

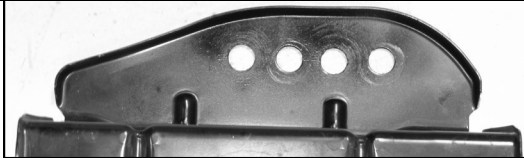

Remove the wood, rotate the canister and skid plate. Reinstall using the two new mounting holes. Torque all three bolts to 10 ft-lbs (14 Nm)

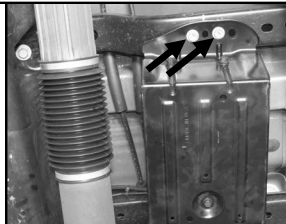

27

Reinstall the wheels and tires.

Torque lug nuts to 85-125 ft-lbs (115-170 Nm) Lower the Jeep to the ground.

With the Jeep on the ground, torque control arm, trackbars, trackbar brackets and all other bolts that have not been tightened. This will ensure that the bushing load is in a neutral position throughout the Jeep.

Front Upper Control Arms	75 ft-lbs	102 Nm
Rear Upper Control Arms	125 ft-lbs	169 Nm
Front and Rear Lower	125 ft-lbs	169 Nm
Front and Rear Trackbars	125 ft-lbs	169 Nm

28

Note: Before test driving the Jeep, do a quick visual check and make sure the tires are straight. Adjust the drag link as needed to center the steering wheel. Drive a short distance down a straight road and, if necessary, readjust the steering wheel to center. Torque the draglink adjusting sleeve to 26 ft-lbs (35 Nm).

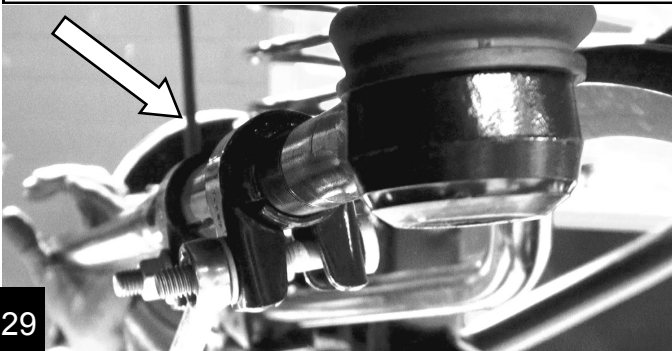

29

Perform a final check of the suspension components and bolts.

To avoid excessive tire wear an alignment is necessary.

Maintenance Note: After the first 100 miles and every 3,000 miles after that, re-torque all the suspension components and bolts.

Install is now Complete!

Congratulations! Your hard work, unprecedented dedication, and extreme attention to detail have earned you a very sweet ride. Go enjoy a day or two in the back country. After all, you earned it.

30

PRODUCT INFORMATION

MAINTENANCE INFORMATION:

It is the buyer's responsibility to have all suspension, drivetrain, steering, and other components checked for proper tightness and torque after the first 100 miles and every 3000 miles after that.

NOTICE TO INSTALLER:

The enclosed "Warning to Driver" sticker must be installed in the vehicle in driver's view. This sticker is to act as a constant safety reminder when operating the vehicle. It is your responsibility as the equipment installer to install the provided sticker and to forward the product instructions to the vehicle's owner for review. If a "Warning to Driver" sticker or product installation guide were not included in the kit, FREE replacement stickers and instructions are available by request. It is the installer's duty to ensure a safe and controllable vehicle after the modifications have been performed.

WARNING:

Neither the seller nor the manufacturer will be liable for any loss, damage, or injury directly or indirectly arising from the use of or inability to determine the use of these products. Before using, the user shall determine the suitability of the products for its intended use, and the user shall assume all responsibility and risk in connection therewith.

WARNING TO DRIVER:

This vehicle has been modified to enhance off road performance and has unique handling characteristics. Use in harsh environments can cause extreme stress on the components. Vehicle should be inspected after being off road to make sure that all the components are in working order and safe to travel on the highway. All fasteners should be checked so that they are at the correct torque specifications as the vibration and stresses from off roading may cause critical fasteners to work loose. Extra care should be taken to inspect the critical components, steering, and brake systems. During each oil change components such as arms, tie rod ends, etc should be greased and checked for excessive wear. Any worn components should be replaced. When returning to the pavement always set or restore tire air pressure to the factory recommendation and connect or engage any disabled swaybar mechanisms. Because of the higher center of gravity and larger tires, this vehicle handles and reacts differently than many passenger cars, both on and off road. You must drive it safely! Extreme care should be taken to prevent vehicle rollover or loss of control, which can result in serious injury or death. Avoid sudden sharp turns or abrupt maneuvers. Generally, braking performance and capabilities are decreased when significantly larger/heavier tires are used, especially when used in combination with transfer case low-range reduction kits. Take this into consideration while driving. Do not add, alter or fabricate any factory or aftermarket parts to increase vehicle height over the intended height of the TeraFlex product purchased. Mixing component brand is not recommended. TeraFlex Inc. will not be responsible for any altered product or any improper installation or use of our products. We will be happy to answer any questions concerning the design, function, and correct use of our products. It is ultimately the buyer's responsibility to have all bolts/nuts checked for tightness after the first 100 miles and then every 3000 miles. Wheel alignment, steering system, suspension and drive line systems must be inspected by a qualified professional mechanic at least every 3000 miles.

TERAFLEX PRODUCT WARRANTY:

TeraFlex Inc. warrants TeraFlex Suspension products to the original retail purchaser to be free of defects in material and workmanship for as long as the original purchaser owns the vehicle on which products were originally installed.

Failure to complete regular maintenance (grease every 3000 miles) on TeraFlex FlexArms will void this warranty. All other conditions of the standard TeraFlex product warranty apply.

All TeraLow products are covered by the TeraFlex two (2) year warranty to be free of defects in material and workmanship for two years from date purchased.

TeraFlex axles are covered by a 12-month warranty to be free of defects in materials and workmanship.

This warranty does not cover or include product finish, improperly installed or applied products, improperly maintained products, products or components used for racing or competition or damage due to abuse or neglect, products that fail due to the use of larger tire and wheel combinations.

All returns must be accompanied by an original invoice. It is the customer's responsibility to remove the product from the vehicle. Shipping charges are the responsibility of the customer. TeraFlex Inc. will pay the return freight if the product meets the terms of warranty.

This warranty is for the replacement or repair of defective TeraFlex products only and does not include freight charges, labor charges for removal of or installation of TeraFlex or related products or components, costs incurred due to down time of the vehicle, or lost profits due to vehicle down time.

A returned goods authorization number (RGA#) must accompany any returned products. For more information please contact a TeraFlex customer service representative.

COPYRIGHT

©Copyright 2014. All rights reserved, TeraFlex Inc. Reproduction of this catalog and/or any of its contents without written permission is strictly prohibited.

TeraFlex® is a registered trademark of TeraFlex Inc. All trade names and logos including but not limited to TeraFlex, FlexArms, RockGuard, Monster, and LCG are protected by law and duplication of trade names and/or logos are strictly prohibited.

TeraFlex Inc. reserves the right to update, discontinue, redesign, modify finish, part number or component build parts if deemed necessary without written notice. TeraFlex Inc., and any associated dealers are not responsible for misprints or typographical errors that may have inadvertently been made within this instruction sheet.

Jeep® and the Jeep® grill are registered trademarks of Fiat Chrysler Automobiles N.V., and have no affiliation with TeraFlex Inc.