



FILTERS

PARTICLE SEPARATOR

INSTALLATION INSTRUCTIONS:

P/N: 76-2008





FILTERS

BREATHE EASY. YOUR ENGINE & WARRANTY ARE PROTECTED.™

Thank You! for purchasing your new S&B Filters particle separator kit. If at any time you need additional assistance with installation or have any other questions or comments, feel free to call our customer service department at 909-947-0015. You can also take advantage of our live chat at www.sbfilters.com and connect with an S&B representative immediately. We hope you enjoy your new S&B Filters product and thank you for your continued support. Breathe Easy. Your Engine and Warranty Are Protected.

VEHICLE APPLICATION:

YEAR: 2013-2017

MAKE: POLARIS

MODEL: RANGER 570 (XP, Full Size, EFI Full-Size Crew), 900 (XP, Crew, XP EU, EPS Poland), Diesel HST/Deluxe, 1000 (XP, Crew), 1000 Diesel (Crew, EU, Poland)

ENGINE: 567cc, 875cc, 999cc, 1028cc (Diesel)

APPROX. INSTALL TIME: 2HRS | 00MIN

TOOLS REQUIRED:

- 4mm, 5mm Hex Key
- 10mm, 13mm Socket/Wrench (*thin 13mm wrench)
- 5/16" Nut Driver or Flat Blade Screwdriver
- Drill
- 5/16" Drill bit
- T40 Torx
- Mini-Bolt or Heavy Duty Wire Cutter
- Razor Blade or Scissor
- Panel Popper

NOTES:

- Kit may not fit with certain Polaris Parts and Accessories. Modification may be required to ensure fit.
- See Step 15 for installation pictures to determine if your accessories will interfere with the mounting positions. If you want to install the Particle Separator on the lower position with a back window installed, you must purchase the S&F Filters Clamp 100mm Spacer Kit (HP1423-00) or put the separator in the farthest position out on the L-bracket so the Particle Separator can get sufficient airflow.

THREAD LOCKER USE



We have provided a small tube of thread locker in your kit. Whenever you see the symbol above on a step of the instructions apply 1 small drop of the thread locker to the threads of the screws or bolts. This will keep your hardware from vibrating loose during rough driving. If the hardware ever needs to be removed, do so slowly to avoid having the inserts strip out from the plastic.

BEFORE YOU START

- Please read the entire product guide before proceeding.
- Ensure all components listed on pages 3 & 4 are present.
- If you are missing any of the components, call our customer support at (909) 947-0015.
- Do not work on your vehicle while engine is hot.
- Make sure the engine is turned off and the vehicle is in Park.

RELATED ITEMS FOR YOUR PURCHASE

Order Online today at www.sbfilters.com or through your local S&B distributor.



Stainless Steel Faceplate (Polished)
SKU# 76-3000



Stainless Steel Faceplate (Brushed)
SKU# 76-3001



Stainless Steel Faceplate (Red)
SKU# 76-3002



Stainless Steel Faceplate (Blue)
SKU# 76-3003



LED Rocker Switch w/ S&B Logo
SKU# HP1432-00



Clamp 100mm Spacer Kit
SKU# HP1423-00



3.5" ID Flexible Ducting (53" Length)
SKU# AI1735-02



Roost Protector
SKU# AM0282-00

WARNING: THIS EQUIPMENT SHOULD BE INSTALLED, ADJUSTED, AND SERVICED BY PERSONNEL FAMILIAR WITH THE CONSTRUCTION AND OPERATION OF THIS TYPE OF EQUIPMENT AND THE HAZARDS INVOLVED. FAILURE TO OBSERVE THIS PRECAUTION COULD RESULT IN SEVERE INJURY. READ THIS MANUAL THOROUGHLY AND MAKE SURE YOU UNDERSTAND THE PROCEDURES BEFORE YOU ATTEMPT TO OPERATE THIS EQUIPMENT. THE PURPOSE OF THIS MANUAL IS TO PROVIDE YOU WITH INFORMATION NECESSARY TO SAFELY OPERATE, MAINTAIN, AND TROUBLESHOOT THIS EQUIPMENT. DO NOT USE THIS EQUIPMENT FOR ANY REASON OTHER THAN ITS INTENDED PURPOSE. FAILURE TO FOLLOW THESE INSTRUCTIONS WILL VOID ANY WARRANTY. KEEP THIS MANUAL FOR FUTURE REFERENCE. THE INFORMATION CONTAINED IN THIS MANUAL IS SUBJECT TO CHANGE WITHOUT NOTICE.

Product will intake and expel both air and loose materials with high force and velocity.

- Install product on roll cage, so air inlet is not blocked.
- Do not place face, hair, extremities, clothing, or other loose material in front of air inlet or outlet during use.
- Install product securely to roll cage and avoid placing hair, extremities, clothing, or other loose material in front of air inlet during use.

Moving parts are sharp and could cause personal injury.

- Keep fan safety guard and exhaust cover in place while operating and after service.
- Disconnect product from power source before servicing.

Scavenge Fan is designed for use in conjunction with an UTV's operating manual, and state and federal law.

- Keep your seat belt fastened and wear a helmet while operating the vehicle.

Risk of electric shock!

- Improper installation, maintenance or operation could cause serious injury or property damage.

EXPLODED VIEW:

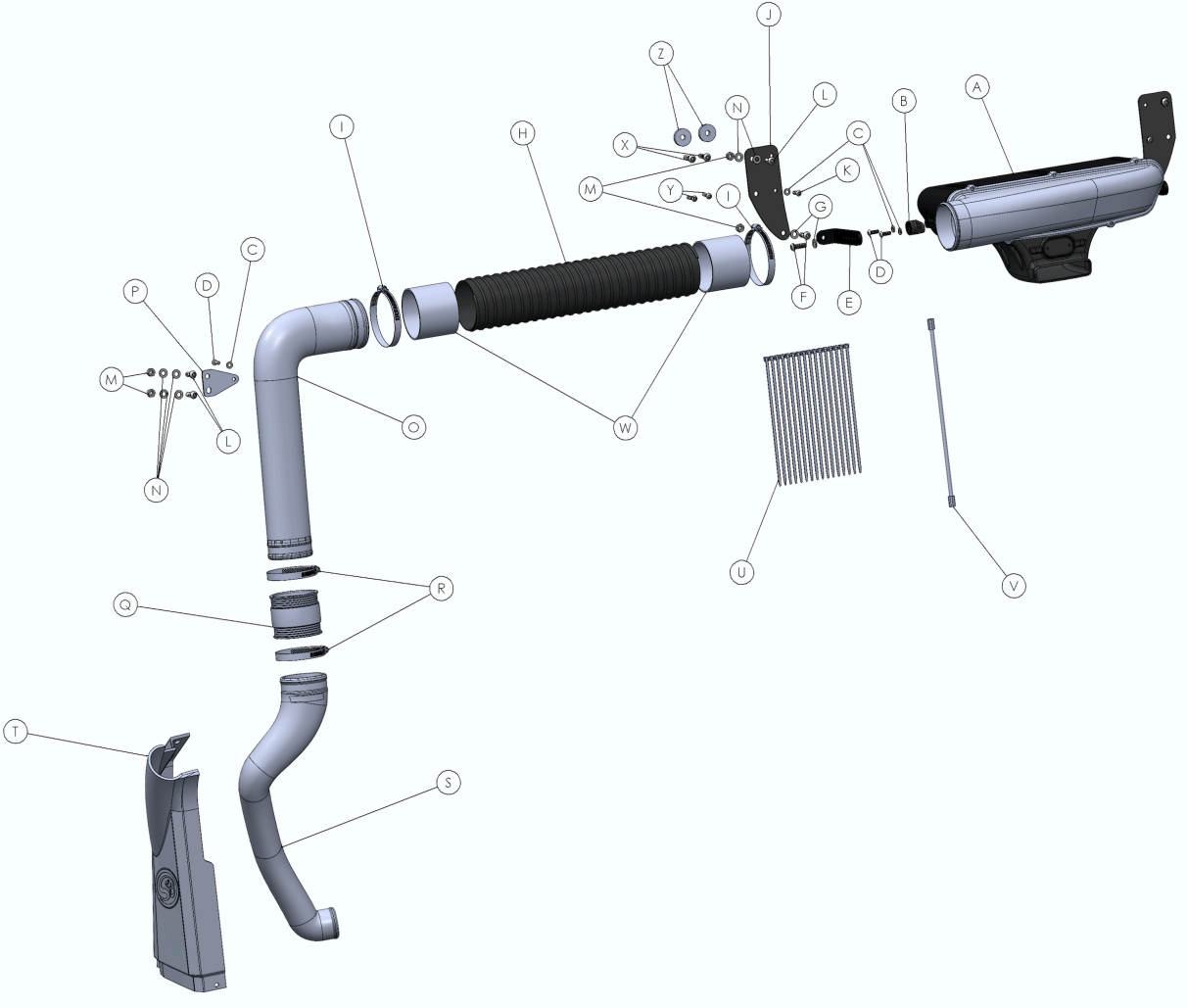

PARTS LIST: 76-2008

ITEM	QTY	DESCRIPTION	PART NUMBER
A	1	PARTICLE SEPARATOR	AL2004-00
B	2	ADAPTER, CLAMP	AI1800-00
C	9	WASHER, M6	AI1755-00
D	5	SCREW, BHCS, M6 x 1mm x 18mm	AI1802-00
E	2	L-BRACKET, CLAMP	AI1781-00
F	4	SCREW, BHCS, M8 x 1.25mm x 25mm	AI1788-00
G	4	WASHER, M8, Oversized	AI1742-00
H	1	3.50" ID Flexible Duct	AI1735-03
I	2	HOSE CLAMP, #56	AG1019-00
J	2	PARTICLE SEPARATOR MOUNTING BRACKET	AI1963-00
K	2	SCREW, M6, SELF-THREADING	AI1983-00
L	4	SCREW, BHCS, M8 x 20mm	AI1979-00
M	6	LOCKNUT, M8 ZINC PLATED	AI1736-00
N	8	WASHER, M8	AI1740-00
O	1	INTAKE TUBE, #2	AL1302-00
P	1	INTAKE TUBE MOUNTING BRACKET	AI1962-00
Q	1	COUPLER	AI1806C-00
R	2	HOSE CLAMP, #48	AG1015-00
S	1	INTAKE TUBE, #1	AL1301-00
T	1	SIDE COVER	AL1300-00
U	16	CABLE TIE, 17" LONG	AI1753-00
V	1	UNIVERSAL WIRE HARNESS	AI1887-00
W	2	FLEXIBLE DUCT END CUFF	AI1865C-00
X	2	SCREW, BHCS, M8 x 35mm	AI1741-00
Y	2	SCREW, BHCS, M6 x 30mm	AI1662-00
Z	2	WASHER, NEOPRENE, 1.25" OD x 0.375"ID	AI1603-00
ITEMS NOT SHOWN IN THE EXPLODED VIEW			
AA	1	VELCRO STRAP	AI1779-01
AB	1	POSI-TAP	AI1799-00

HARDWARE PACKS

HP-1466-00
 AI1800-00
 AI1781-00
 AI1963-00
 HP1467-00
 AI1788-00
 AI1802-00
 AI1755-00
 AI1979-00
 AI1736-00
 AI1740-00
 AI1983-00
 AI1742-00
 AI1595-00
 HP1497-00
 AI1755-00
 AI1741-00
 AI1662-00
 AI1603-00
 HP1468-00
 HP1469-00
 AI1962-00
 AI1802-00
 AI1736-00
 AI1979-00
 AI1740-00
 AI1755-00
 AI1865C-00
 AG1015-00
 AG1019-00
 HP1496-00
 AI1887-00
 AI1799-00
 AI1753-00
 AI1779-01

AIM03900 REV-B 12/14/2017

INSTALLATION STEPS:

- 1** Remove the stock side cover on the driver side. Pull on the handle to lift the bed up to get more room to work with.



- 2a** Remove the three fasteners in front of the side cover. Remove the two top screws and panel clip rivet. If necessary, remove any accessories in the way. Set aside all fasteners removed, they will be reused.
Tool Required: T40 Torx, Panel Popper



- 2b** Remove the two fasteners behind the side cover. Remove the panel clip rivet on top and bottom screw. Set aside only the screw. The panel clip will not be used.
Tool Required: T40 Torx, Panel Popper

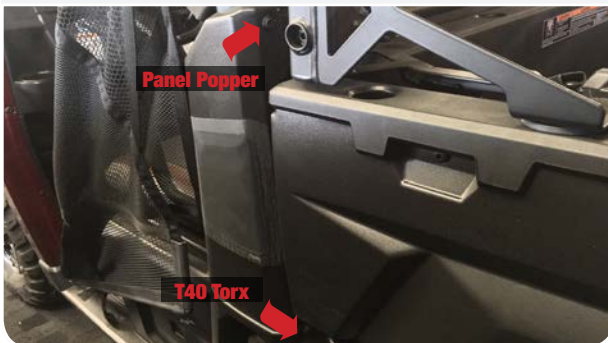

- 3** Loosen the hose clamp on the intake duct connected to the side cover.

Tool Required: 5/16" Nut Driver or Flat Blade Screwdriver



- 4** Lift up and disconnect the side cover from the intake duct, then remove the side cover.



- 5** Remove the intake coupler from the stock side cover.

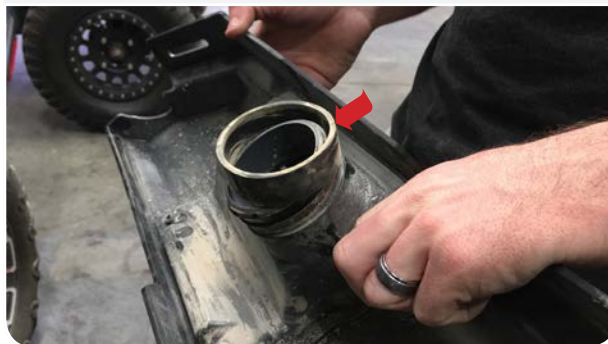

- 6** (Optional-Door Hinges installed behind Side Cover) Go to Page 14 for a cutout template to help clear your hinges before installed the Replacement Side Cover (T). Line up the sides and bottom then use tape to secure the template then use a cutting tool to cut out a notch.



- 7a** Slid the stock coupler onto the Intake Tube #1 (S) and then into the stock intake inlet.



- 7b** Do not fully tighten the hose clamp. Adjustments may be needed after the Replacement Side Cover (T) is installed.
Tool Required: 5/16" Nut Driver or Flat Blade Screwdriver



- 8** Install the Intake Tube Mounting Bracket (P) onto Intake Tube #2 (O) with the M6 Screw (D) and Washer (C). Make sure that the bracket is in the same position as shown below. The bracket should be completely horizontal.
Tool Required: 4mm Hex Key



- 9** Connect Intake Tube #1 (S) and #2 (O) with the Coupler (Q) and #52 Hose Clamps (R). Leave the hose clamps loose.
Tool Required: 5/16" Nut Driver or Flat Blade Screwdriver



- 10** Secure Intake Tube #2 (O) onto the roll cage tab with the M8 Screws (L), Washers (N), and Locknuts (M). Tighten both #52 Hose Clamps (R) at the Coupler (Q).
Tool Required: 5/16" Nut Driver or Flat Blade Screw Driver, 5mm Hex Key, thin 13mm Wrench



INSTALLATION STEPS:

- 11** Install the Replacement Side Cover (T). Adjust Intake Tube #1 (S) as needed then tighten the hose clamp on the stock intake inlet from Step 7.



- 12a** Install the fasteners removed in Step 2 and secure the Replacement Side Cover (S).
Tool Required: T40 Torx

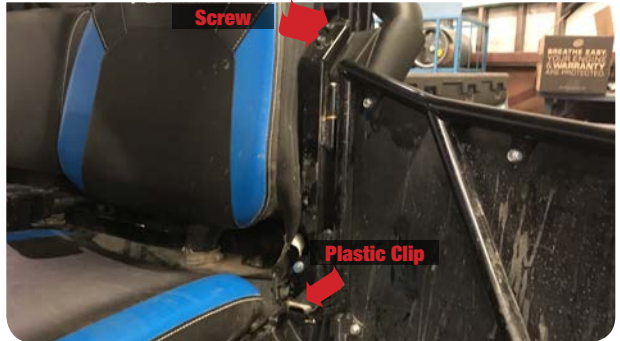

- 12b** ...Continue from previous step.

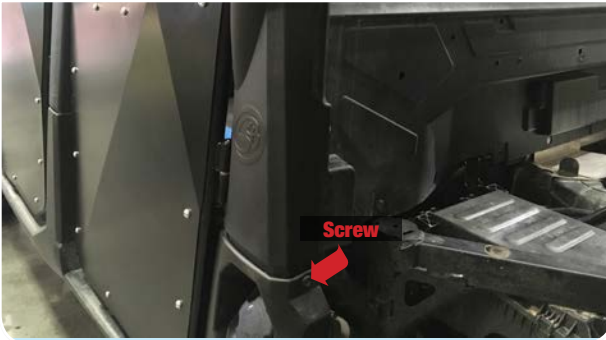

- 13** Install the Adapter (B) on the mounting bosses of the Particle Separator (A) with the M6 Screws (D) and Washers (C). Tighten these screws. Repeat for the other side.
Tool Required: 4mm Hex Key



- 14** When installing the L-Bracket make sure that the mounting tab is facing outward as shown below and the ribs in the L-Bracket are properly seated inside the grooves of the adapter. Do not attempt to rotate these parts once assembled. The L-Bracket can only be installed completely horizontal. They are designed to lock into place once seated. Once you're satisfied with these configurations apply Threadlocker to the M8 Screw (F) and tighten with a Washer (G). Repeat for the other side of the Particle Separator (A) and make sure the L Bracket on both sides are pointed in the same direction and are aligned with each other.
Tool Required: 5mm Hex Key



- 15** Determine which position you want to mount the Particle Separator (A). Make sure you have enough clearance to install the Particle Separator Bracket (J) without any interference. **Note:** If you want to install the Particle Separator on the lower position with a back window installed, you must purchase the S&F Filters Clamp 100mm Spacer Kit (HP1423-00) or put the separator in the farthest position out on the L-bracket so the Particle Separator can get sufficient airflow.

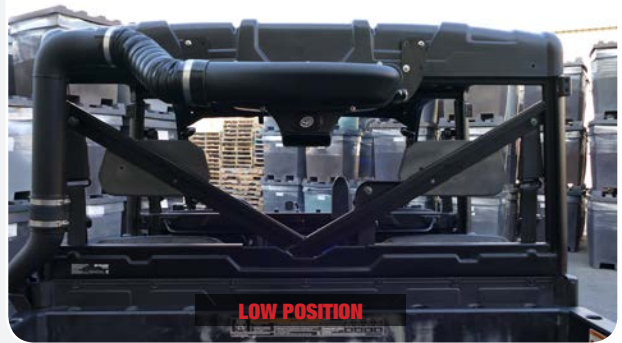
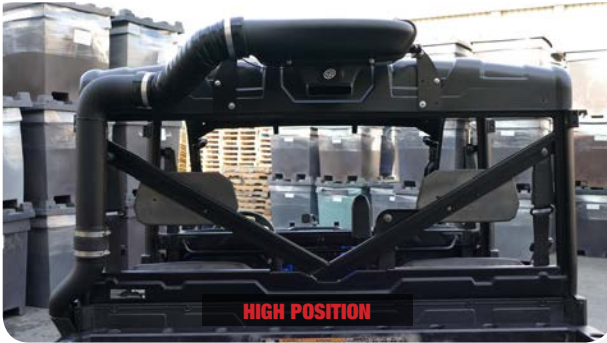

- 16** For vehicles with Roof Installed Only (skip to Step 17 if this does not apply to you): To install the Particle Separator Bracket (J), we will use four existing holes on the factory roll cage. If you have a factory or after market roof the top holes might be blocked and will need to be drilled out. **Note:** Only drill out the two holes. The bottom holes are already tapped. **Tool Required:** Drill, 5/16" Drill Bit



- 17** At the mounting locations determined in Step 15, install the Particle Separator Mounting Brackets (J) onto the roll cage. The longer side of the mounting bracket must be faced inward. Secure the top hole using the M8 Screws (L), Washers (N), Locknuts (M). Only install the Neoprene Washer (Z) if a roof is installed otherwise leave it out. The neoprene washer goes behind the mounting bracket. **Note:** If there is no roof installed, use the M6 Self Threading Screws (K). Otherwise secure with the M6 Screws (Y) and Washers (C). The neoprene washer is not needed without a roof. Repeat for the other side. **Tool Required:** 4mm Hex Key, 5mm Hex Key, 10mm Wrench Socket (M6 Self Threading Screw), 13mm Wrench/Socket

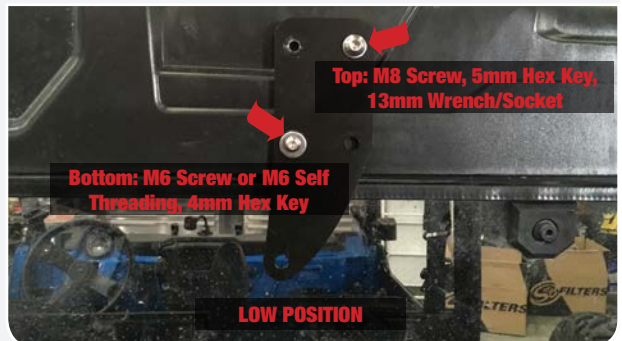
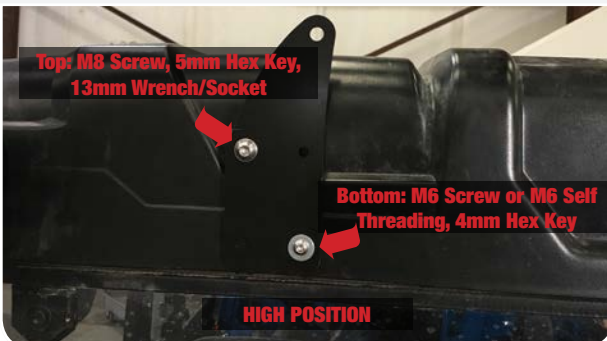

INSTALLATION STEPS:

- 18** Install the Particle Separator (A) onto the Particle Separator Mount Brackets (J) with the M8 Screws (F), Washers (G), and Locknuts (M).
Tool Required: 5mm Hex Key, 13mm Wrench/Socket



- 19** Go over all screws and locknuts again to make sure they are secure and that the Particle Separator (A) is firmly secured to the roll cage.



- 20** Insert one end of the Flexible Duct (H) onto Intake Tube #2 (O) and bring the other end towards the plenum on the Particle Separator (A). Note the length on the duct you want to cut. We recommend cutting the duct longer so that the ends, along with any wire and strings, can be folded in for a cleaner look.



- 21** Pierce the Flexible Duct (H) using a razor, centered between the two wire reinforcements. Cut all the way around. Try to cut the duct straight around the center as close as possible.
Tool Required: Razor Blade



- 22** Use scissors to begin the cut. Aim the scissors towards the start of the cut. Do not try to cut through the wire with scissors. Use a mini-bolt or heavy duty wire cutter to finish cutting through the wire and strings.
Tool Required: Scissors, Mini-Bolt or Heavy Duty Wire Cutter



23 (Optional) Install Flexible Duct End Cuff (W) onto both ends of the Flexible Duct (H) with #56 Hose Clamps (I) installed. Do not tighten .



24 Install the Flexible Duct (H) onto the plenum of the Particle Separator (A) and Intake Tube #2 (O) Tighten all hose clamps. If needed, use Velcro Strap (AA) to secure the duct. **Tool Required:** 5/16" Nut Driver or Flat Blade Screwdriver



25 Familiarize yourself with the Wire Harness (V) and each of the connectors. Coming from the relay should be a pig tail, fan connector and ring terminals. Pig Tail Wire is used in conjunction with the Posi-Tap (AB) to tap into a power source. Ring Terminals have the fuse holder with the red and black ring terminals for the battery. Fan Connector has the connector to power the Particle Separator (A).

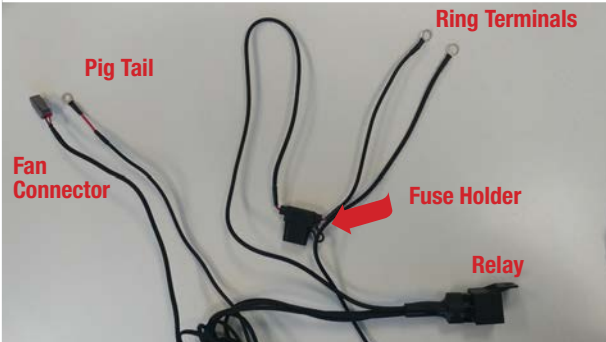

26 Loosen and remove the screw on the negative battery terminal, then disconnect the positive terminal from the battery. Install the Ring Terminals, from the Wire Harness (V), onto the battery terminal clamps. Red wire with the fuse holder to (+) and Black wire to (-) and reinstall the screw. Secure the positive terminal first then the negative terminal. **Tool Required:** 13mm Wrench/Socket

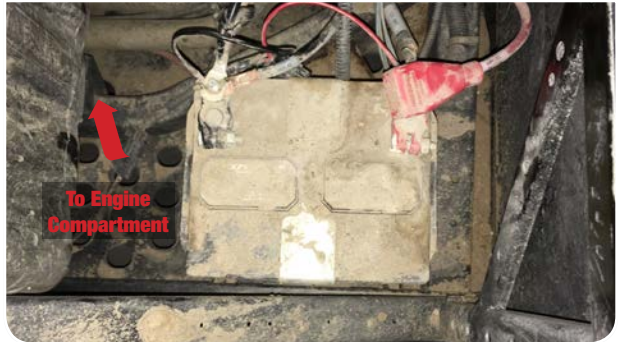

27 Route the Wire Harness (V) towards the taillight connector should be routed through the vehicle in such a way that the wire harness is protected from direct contact with flying dirt/rocks and other moving parts on the vehicle. You want to tap into the red wire (signal wire) on the tail light in the next step.

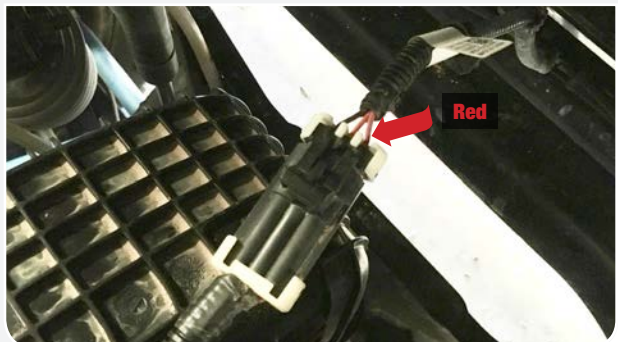
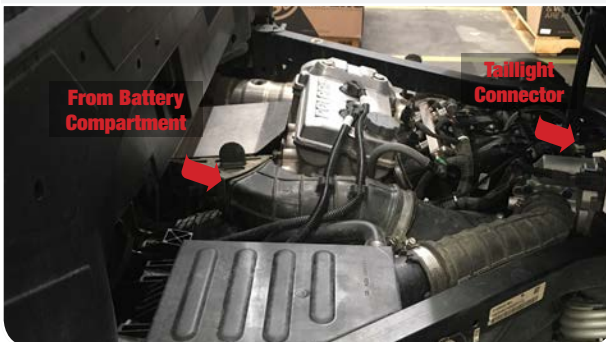

INSTALLATION STEPS:

- 28** Unscrew the large top cap and place the cap around the red wire on the taillight connector then screw the body onto the cap until it is firmly tight and pierces the wire.



- 29** The Pig Tail wire comes with a ring terminal that could be connected to a powered terminal bus bar. If you do not have one on your UTV, cut off the terminal and strip about 3/8" of insulation off of the end of the Pig Tail wire. Unscrew the bottom cap on the Posi-Tap (AB) and insert the Pig Tail wire into the main body of the Posi-Tap. Make sure the strands go around the metal core. While holding the wire in place, screw the bottom cap back on until it is firmly tight. Double check both caps to make sure they are tight.



- 30** To ensure that you have installed the Wire Harness (V) correctly, connect the Fan Connector to the fan on the Particle Separator (A). Note the color of the wires whenever connecting or disconnecting this connector. Make sure not to cross the connectors. Power (red) to power (red) and ground (black) to ground (black). The connector should snap into each other with very little resistance. Do not try to force the connectors into each other. Turn the key one position clockwise (without bumping the starter) or if you have wired in a switch, flip the switch to the ON position. If you hear the Particle Separator fan turning on, you have wired it correctly. Proceed to the next step.



31 Disconnect the connector and finish the wiring. Route the wire as you see fit towards the Particle Separator (A).

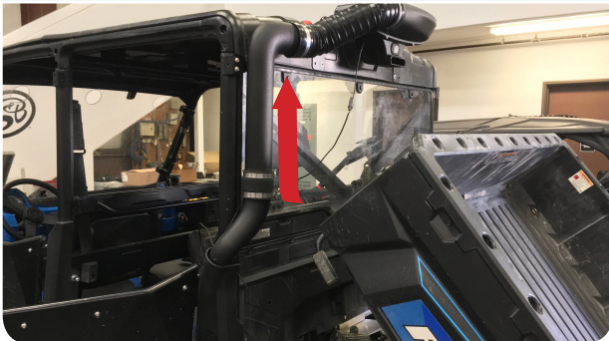

32 Connect the fan connector into the Particle Separator (A). Use Cable Ties (U) or Velcro Strap (AA) to secure the Wire Harness (V).
Tool Required: Wire Cutter



33 Group together any excess wires and tie them together with the provided Cable Ties (U). Secure the harness in a place away from any exhaust components or moving parts.
Tool Required: Wire Cutter



34 Double check to make sure all connectors are plugged in and secured. Turn the ignition on and make sure air is blowing out the exhaust. If the exhaust fan does not turn on, double check your electrical wiring. Your installation is now complete.



INSTALLATION NOTES:

CUTOUT TEMPLATE:

