

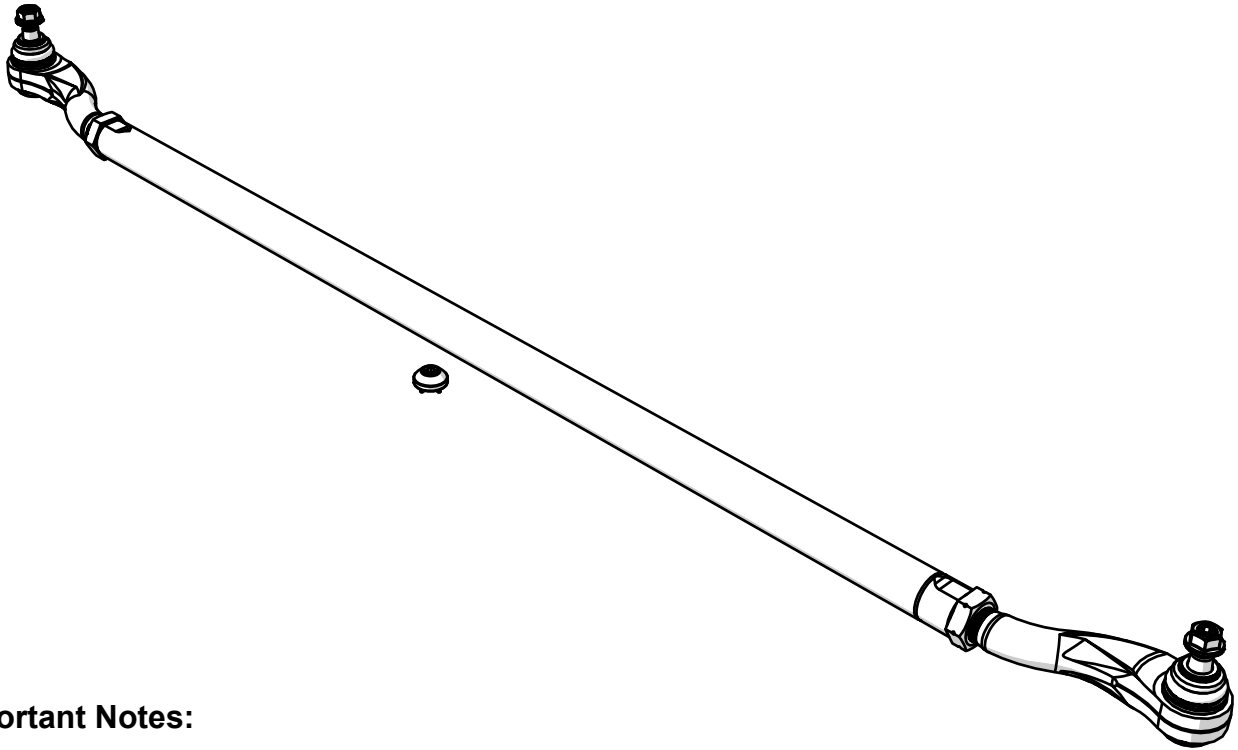

# TeraFlex JK Premium HD Tie Rod Kit

www.teraflex.com

Kit #1853910



## Important Notes:

Prior to beginning this or any installation read these instructions to familiarize yourself with the required steps and evaluate if you are experienced and capable to personally perform these modifications. A factory service manual should be used in conjunction with these installation instructions.

Refer to the parts list to ensure that all necessary components and hardware has been included. If any parts are missing please contact your local TeraFlex dealer for assistance.

An alignment by a professional shop after this installation is highly encouraged and will result in the best performance from your Jeep and your new parts.

The factory steering stabilizer clamp will not fit on your new HD tie rod. Any aftermarket 1-5/8" steering stabilizer clamp will fit.

## Tools needed:

- This installation guide
- Jack
- Jack Stands
- Basic mechanics tool set
- 2.5mm Allen Wrench
- 1-1/2" Open End Wrench
- 1-11/16" Open End Wrench
- Hammer
- Blue LocTite
- Tape Measure

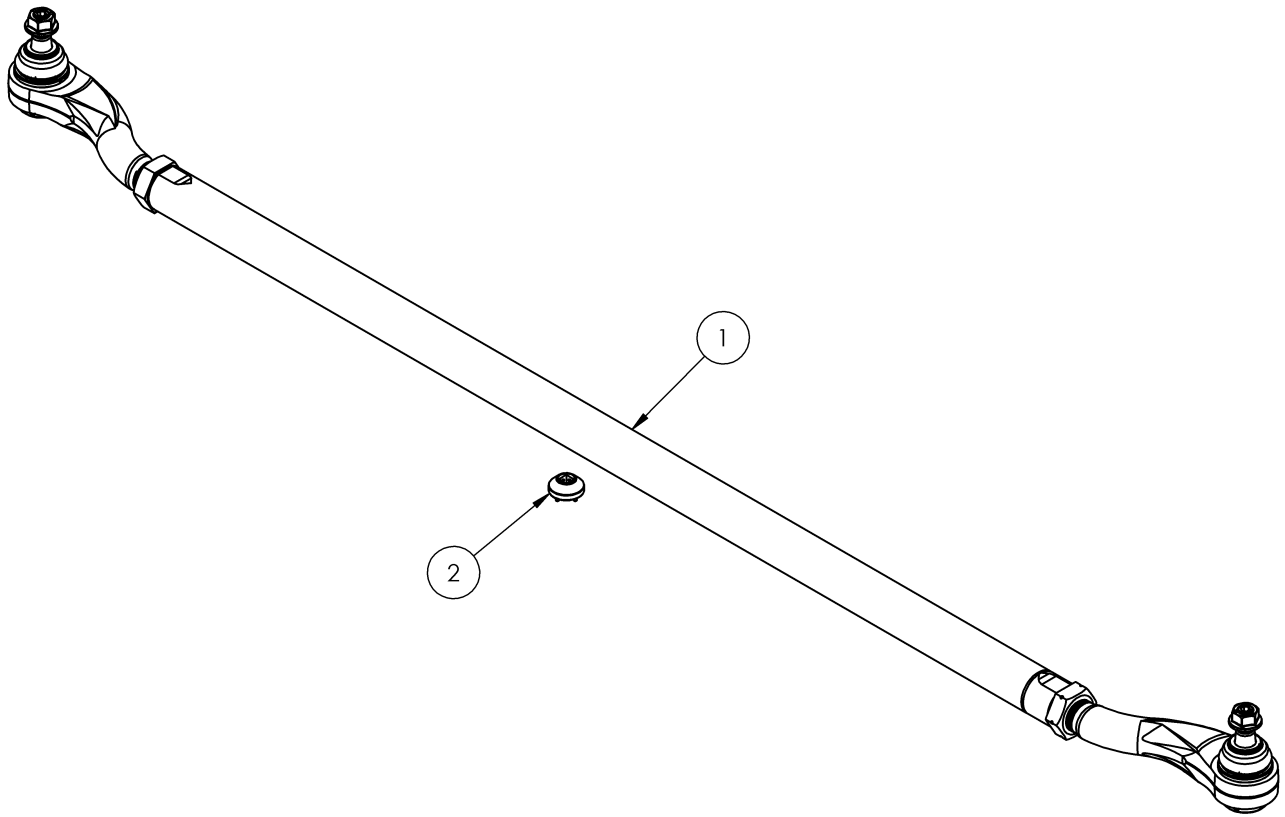

ITEM NO.	PART NUMBER	DESCRIPTION	1853910/ QTY.
1	853915	JK HD Chromoly Tie Rod Assembly with Premium Ball Joints	1
2	344000	HD Ball Joint Adjusting Tool	1
3	999180	Instructions for JK HD Tie Rod Kit	1
4	700137	JK Forged Tie Rod Box	1

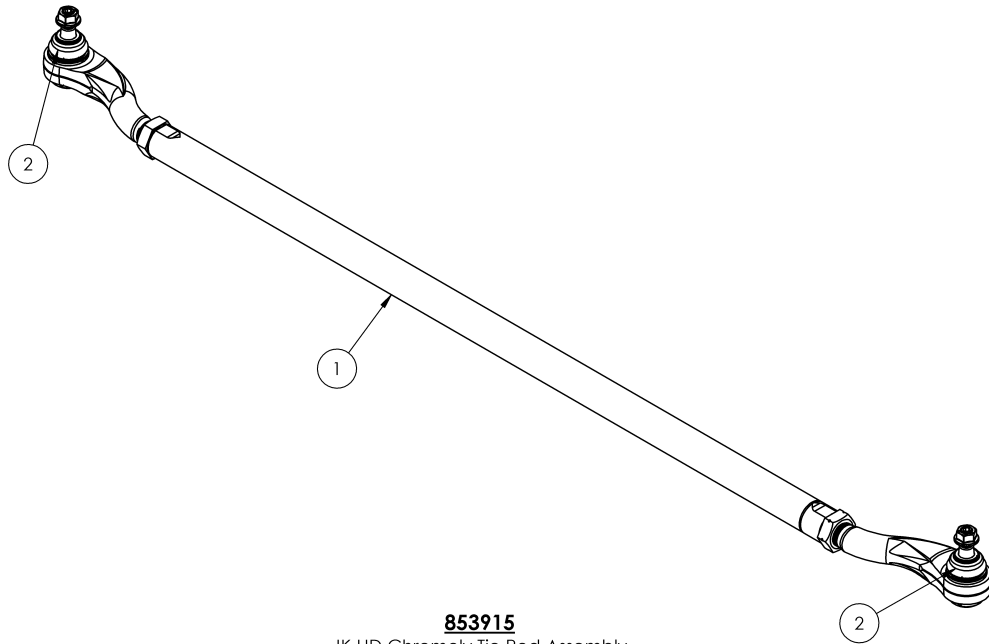

**853915**  
JK HD Chromoly Tie Rod Assembly  
with Premium Ball Joints

ITEM NO.	PART NUMBER	DESCRIPTION	853915/QTY.
1	853910	JK HD Chromoly Tie Rod with Forged Ends	1
2	344410	Premium JK Steering Ball Joint	2

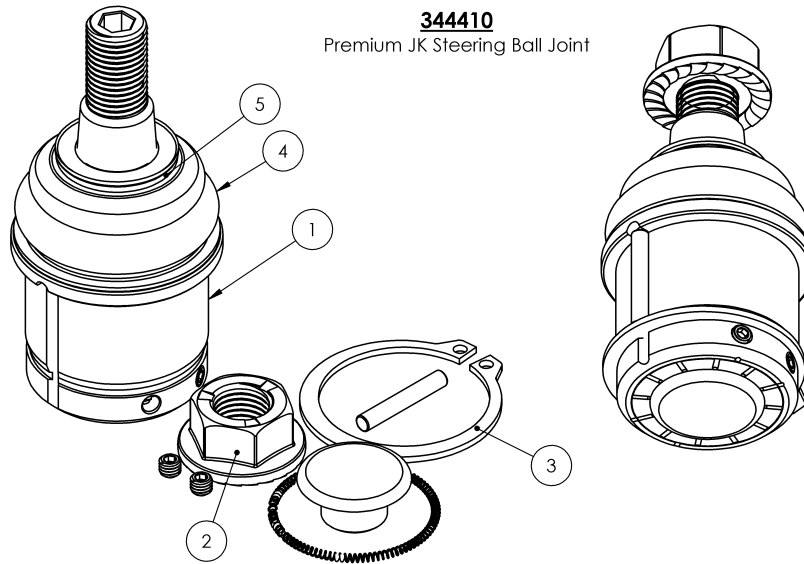

**344410**  
Premium JK Steering Ball Joint

ITEM NO.	PART NUMBER	DESCRIPTION	344410/QTY.
1	344400	JK HD Steering Ball Joint Stud and Housing Assembly	1
2	344415	Premium JK Steering Ball Joint Hardware Pack	1
3	344416	Premium JK Steering Ball Joint Production Hardware Pack	1
4	344405	Premium JK Steering Ball Joint Bi-Fold Dust Boot	1
5	344406	Premium JK Steering Ball Joint Dust Boot Retaining Ring	1

ITEM NO.	PART NUMBER	DESCRIPTION	QTY.
1	212	M14X1.5 Flanged Serrated Distorted Thread Locknut for HD Steering Ball Joints	1
2	304	Set Screw M5 x 0.8 Pitch x 4mm Flat Point for HD Adjustable Ball Joints	2
3	306	Set Screw M5 x 0.8 Pitch Extended Point for HD Adjustable Ball Joints	2
4	308	Grease Zerk 1/4"-28 UNF Straight	1
5	344207	Tool Steel Washer for HD Series Ball Joints	1
6	344208	O-Ring 32mm I.D. 1.5mm Thick for HD Series Ball Joints	1
7	344401	JK HD Steering Ball Joint Rolled Pin Alignment Key	1
8	344402	JK HD Steering Ball Joint Housing	1
9	344403	JK HD Steering Ball Joint End Plate	1
10	344404	JK HD Steering Ball Joint Stud	1
11	344405	Premium JK Steering Ball Joint Bi-Fold Dust Boot	1
12	344406	Premium JK Steering Ball Joint Dust Boot Retaining Ring	1
13	344407	Premium Series Steering and Lower Ball Joint Dust Boot Retaining Spring	1
14	344408	JK HD Steering Ball Joint Grease Zerk Rubber Plug	1
15	845	Snap Ring 1.625" External for HD Series Steering and Axle Ball Joints	1

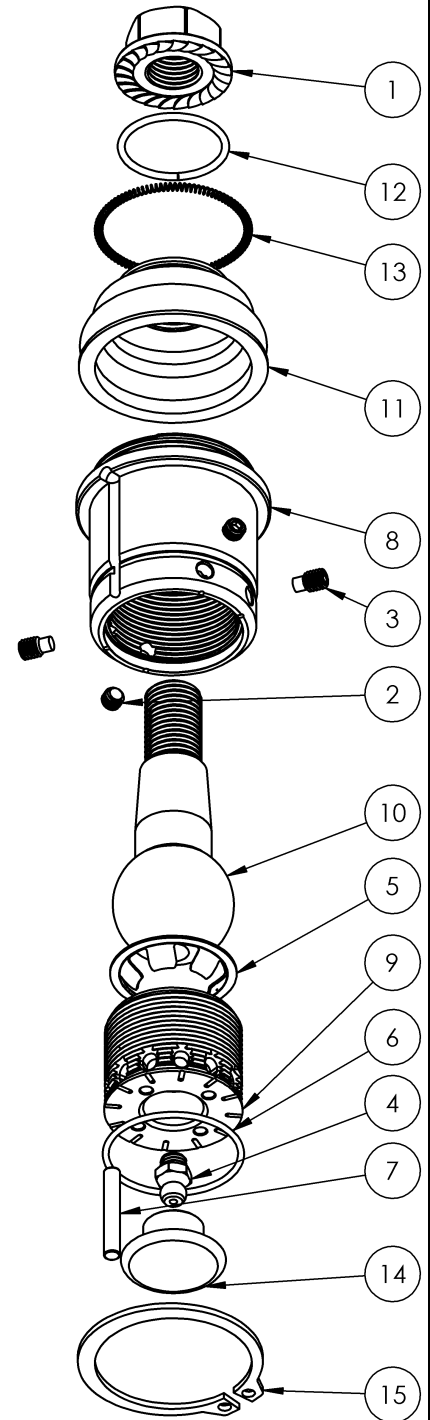

**344410**  
Premium JK Steering Ball Joint

Start your install with safety in mind. Begin by chocking your rear tires. Raise and support the front of the Jeep so that the tires are off the ground. Remove the front tire and wheel assemblies.

1

Remove the steering stabilizer.

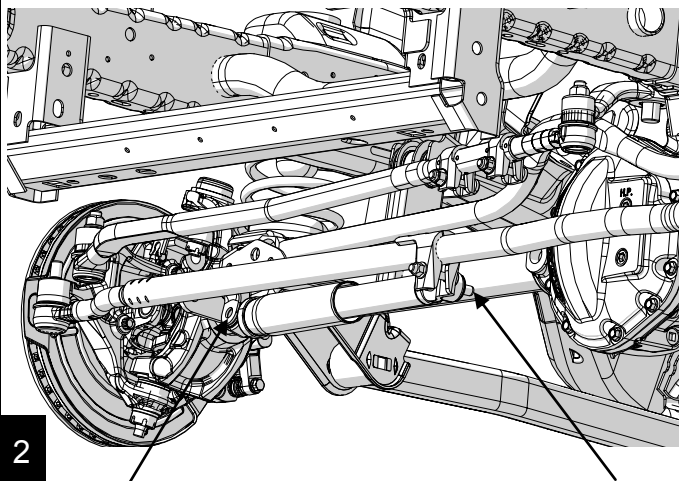

2

Using a 21mm socket, loosen both tie rod end nuts, but do not completely remove. Leave the nuts threaded on a few threads to prevent the tie rod from falling to the floor when broken loose from the knuckle.

Use a hammer to strike around the knuckle casting, perpendicular to the tie rod end stud, until the tie rod falls and is free from the knuckle. Finish unthreading the tie rod nuts and remove the tie rod.

(NOTE: Do not hit the tie rod end stud/threads to free the tie rod. This will destroy the threads.)

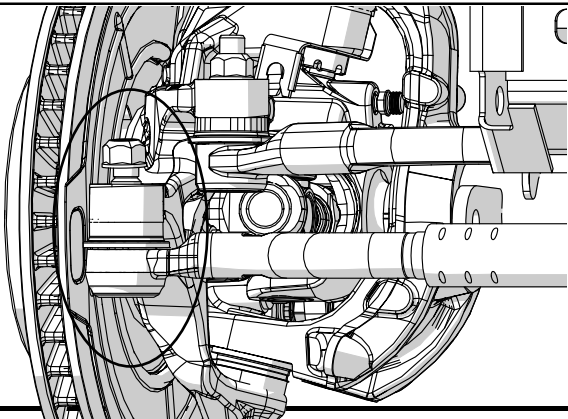

3

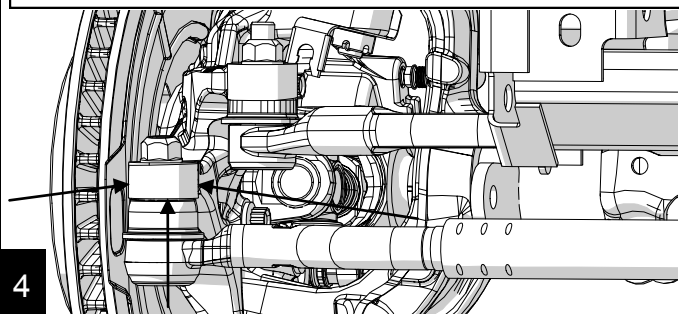

4

Prep your new TeraFlex Premium HD Chomoly Tie Rod for installation by installing the following:

- #344407 Dust Boot Retaining Spring (1 Qty. per tie rod end)
- #304 Set Screw Plug. Use blue Loctite. (2 Qty. per tie rod end)

Refer to the parts list on page 4 for part identification.

(NOTE: Extra O-Rings are included for future maintenance and do not need to be installed in initial setup)

5

Measure your factory tie rod from the center of the tie rod end to the center of the tie rod end on the other side. Adjust your new TeraFlex tie rod to match as closely as possible. Install your new tie rod and Torque the tie rod end nuts to 63 ft. lbs.

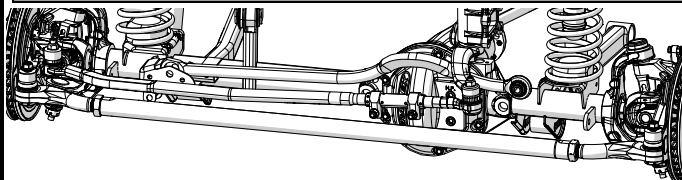

6

Verify that your tie rod length measurement still matches the factory tie rod as closely as possible and tighten the jam nuts. It is important to make sure that after tightening the jam nuts, the tie rod ends on both sides can return to a neutral position and are not bound up.

(NOTE: The tie rod assembly should be able to rotate up and down a few degrees. This is normal and allows for a degree change in the knuckles when turning, without breaking the jam nuts loose.)

Finish your installation by greasing the premium joints of your new TeraFlex tie rod with a quality grease and install #344408 Grease Zerk Dust Cover.

A professional alignment is highly recommended and suggested to completely finish off this installation.  
Enjoy your new TeraFlex HD Tie Rod!

7

8

## PRODUCT INFORMATION

### MAINTENANCE INFORMATION:

It is the buyer's responsibility to have all suspension, drivetrain, steering, and other components checked for proper tightness and torque after the first 100 miles and every 3000 miles after that.

### NOTICE TO INSTALLER:

The enclosed "Warning to Driver" sticker must be installed in the vehicle in driver's view. This sticker is to act as a constant safety reminder when operating the vehicle. It is your responsibility as the equipment installer to install the provided sticker and to forward the product instructions to the vehicle's owner for review. If a "Warning to Driver" sticker or product installation guide were not included in the kit, FREE replacement stickers and instructions are available by request. It is the installer's duty to ensure a safe and controllable vehicle after the modifications have been performed.

### WARNING:

Neither the seller nor the manufacturer will be liable for any loss, damage, or injury directly or indirectly arising from the use of or inability to determine the use of these products. Before using, the user shall determine the suitability of the products for its intended use, and the user shall assume all responsibility and risk in connection therewith.

### WARNING TO DRIVER:

This vehicle has been modified to enhance off road performance and has unique handling characteristics. Use in harsh environments can cause extreme stress on the components. Vehicle should be inspected after being off road to make sure that all the components are in working order and safe to travel on the highway. All fasteners should be checked so that they are at the correct torque specifications as the vibration and stresses from off roading may cause critical fasteners to work loose. Extra care should be taken to inspect the critical components, steering, and brake systems. During each oil change components such as arms, tie rod ends, etc should be greased and checked for excessive wear. Any worn components should be replaced. When returning to the pavement always set or restore tire air pressure to the factory recommendation and connect or engage any disabled sway bar mechanisms. Because of the higher center of gravity and larger tires, this vehicle handles and reacts differently than many passenger cars, both on and off road. You must drive it safely! Extreme care should be taken to prevent vehicle rollover or loss of control, which can result in serious injury or death. Avoid sudden sharp turns or abrupt maneuvers. Generally, braking performance and capabilities are decreased when significantly larger/heavier tires are used, especially when used in combination with transfer case low-range reduction kits. Take this into consideration while driving. Do not add, alter or fabricate any factory or aftermarket parts to increase vehicle height over the intended height of the TeraFlex product purchased. Mixing component brand is not recommended. TeraFlex Inc. will not be responsible for any altered product or any improper installation or use of our products. We will be happy to answer any questions concerning the design, function, and correct use of our products. It is ultimately the buyer's responsibility to have all bolts/nuts checked for tightness after the first 100 miles and then every 3000 miles. Wheel alignment, steering system, suspension and drive line systems must be inspected by a qualified professional mechanic at least every 3000 miles.

### TERAFLEX PRODUCT WARRANTY:

TeraFlex Inc. warrants TeraFlex Suspension products to the original retail purchaser to be free of defects in material and workmanship for as long as the original purchaser owns the vehicle on which products were originally installed.

Failure to complete regular maintenance (grease every 3000 miles) on TeraFlex FlexArms will void this warranty. All other conditions of the standard TeraFlex product warranty apply.

All TeraLow products are covered by the TeraFlex two (2) year warranty to be free of defects in material and workmanship for two years from date purchased.

TeraFlex axles are covered by a 12-month warranty to be free of defects in materials and workmanship.

This warranty does not cover or include product finish, improperly installed or applied products, improperly maintained products, products or components used for racing or competition or damage due to abuse or neglect, products that fail due to the use of larger tire and wheel combinations.

All returns must be accompanied by an original invoice. It is the customer's responsibility to remove the product from the vehicle. Shipping charges are the responsibility of the customer. TeraFlex Inc. will pay the return freight if the product meets the terms of warranty.

This warranty is for the replacement or repair of defective TeraFlex products only and does not include freight charges, labor charges for removal of or installation of TeraFlex or related products or components, costs incurred due to down time of the vehicle, or lost profits due to vehicle down time.

A returned goods authorization number (RGA#) must accompany any returned products. For more information please contact a TeraFlex customer service representative.

### COPYRIGHT

©Copyright 2014. All rights reserved, TeraFlex Inc. Reproduction of this catalog and/or any of its contents without written permission is strictly prohibited.

TeraFlex® is a registered trademark of TeraFlex Inc. All trade names and logos including but not limited to TeraFlex, FlexArms, RockGuard, Monster, and LCG are protected by law and duplication of trade names and/or logos are strictly prohibited.

TeraFlex Inc. reserves the right to update, discontinue, redesign, modify finish, part number or component build parts if deemed necessary without written notice. TeraFlex Inc., and any associated dealers are not responsible for misprints or typographical errors that may have inadvertently been made within this instruction sheet.

Jeep® and the Jeep® grill are registered trademarks of Fiat Chrysler Automobiles N.V., and have no affiliation with TeraFlex Inc.