



Jeep JL 1.5" Spacer Lift

www.teraflex.com

Kit #1165100 - Jeep JL Wrangler, 2DR 1.5" Spacer Lift Kit

Kit #1165002 - Jeep JL Wrangler, 2DR ST1, No Shocks

Kit #1165121 - Jeep JL Wrangler, 2DR S/T1 Kit, 2.1 Falcon Shocks

Kit #1165200 - Jeep JL Wrangler, 4DR 1.5" Spacer Lift

Kit #1165000 - Jeep JL Wrangler, 4DR ST1, No Shocks

Kit #1165021 - Jeep JL Wrangler, 4DR S/T1 Kit, 2.1 Falcon Shocks

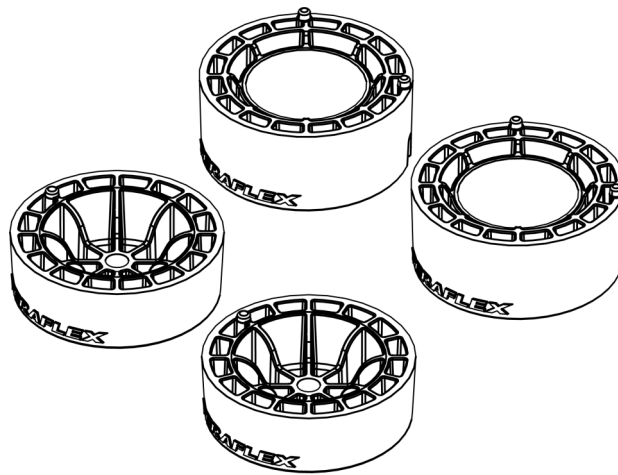

IMPORTANT NOTES:

Prior to beginning this install, or any installation, *read the instructions thoroughly* to familiarize yourself with the required steps. Evaluate if you are experienced and capable to personally perform these modifications. A factory service manual should be used in conjunction with these installation instructions.

This product will change the highway handling characteristics of your vehicle, exercise caution. After altering the suspension it is always advisable to have an alignment done by a competent 4 wheel drive shop or by an alignment shop that is experienced with lifted 4 wheel drive vehicles.

Refer to the parts list to ensure that all necessary components and hardware has been included. If any parts are missing please contact your local TeraFlex dealer for assistance.





Refer to the factory service manual for the torque specs of the originally equipped hardware.

TOOLS NEEDED:

- This installation guide
- Basic mechanics tool set
- Factory Service Manual

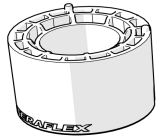
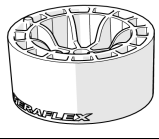
MAINTENANCE INFORMATION:

It is the buyer's responsibility to have all suspension, drivetrain, steering, and other components checked for proper tightness and torque after the first 300 miles and every 3000 miles after that.

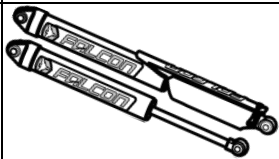
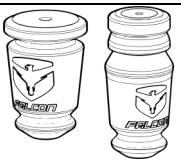
Item #	Description	Part No.	Base Kit		S/T1		S/T1 w/o Shocks	
			2DR	4DR	2DR	4DR	2DR	4DR
1		05-01-109-100	2	-	2	2	-	2
		05-01-109-200	-	2	-	-	2	-
2		05-01-209-150	2	2	2	2	2	2
3		23-07-03-001	2	2	2	2	2	2
4		45-01-003-006	2	2	2	2	2	2
5		45-04-003-001	2	2	2	2	2	2
6		47-02-001-001	2	2	2	2	2	2
7		11-01-21-400-000-3	-	-	1	1	-	-
8		1959200	-	-	1	1	1	1

LIFT AND SUPPORT AT FRAME

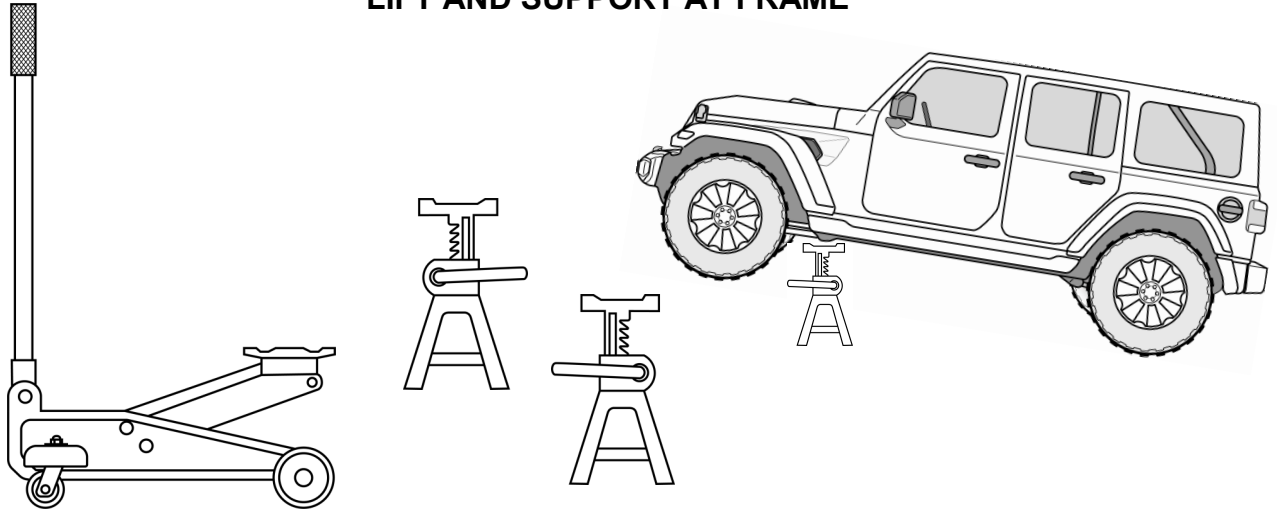

REMOVE TIRES & WHEELS

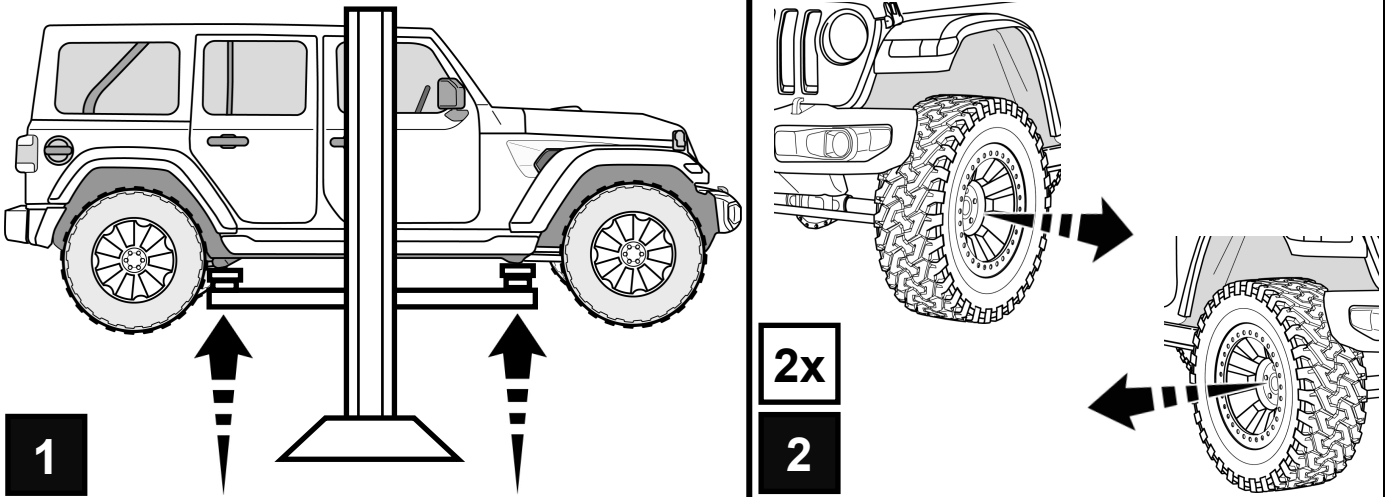

SUPPORT FRONT AXLE

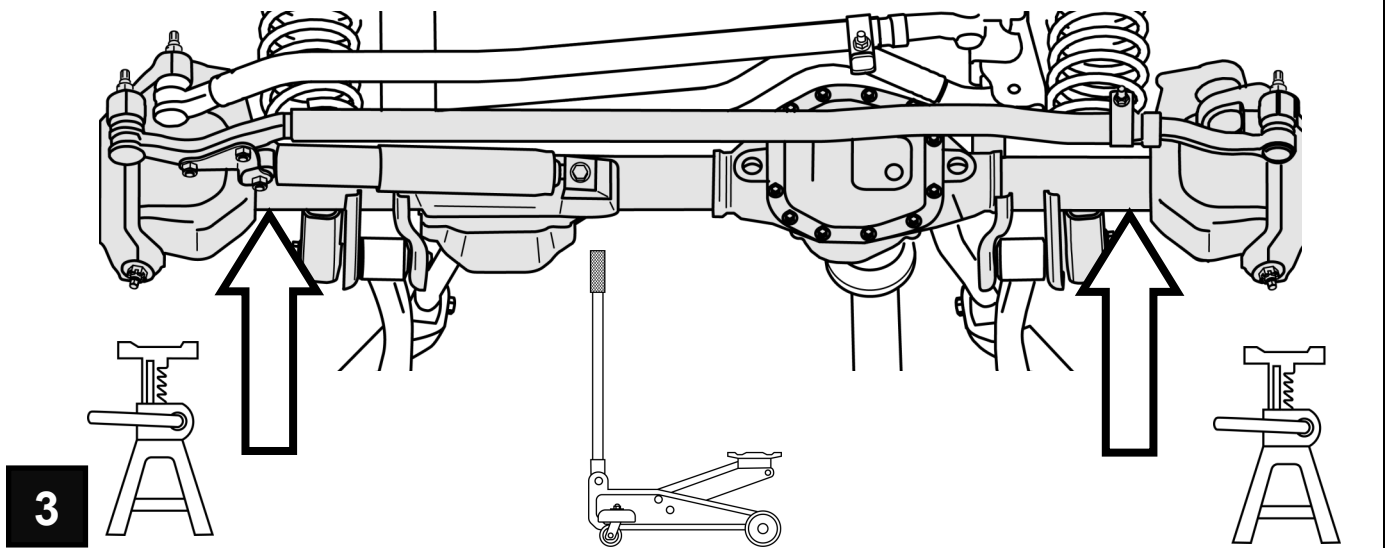

REMOVE SWAY BAR LINK & TRACK BAR AT THE AXLE

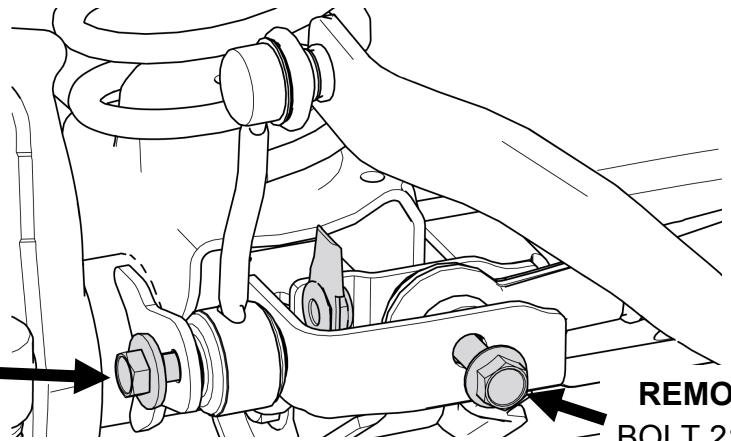
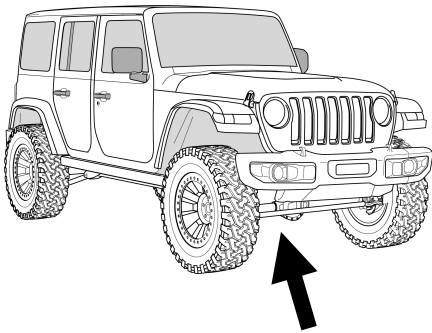

**REMOVE
BOLT 18mm**

**REMOVE
BOLT 21mm**

4

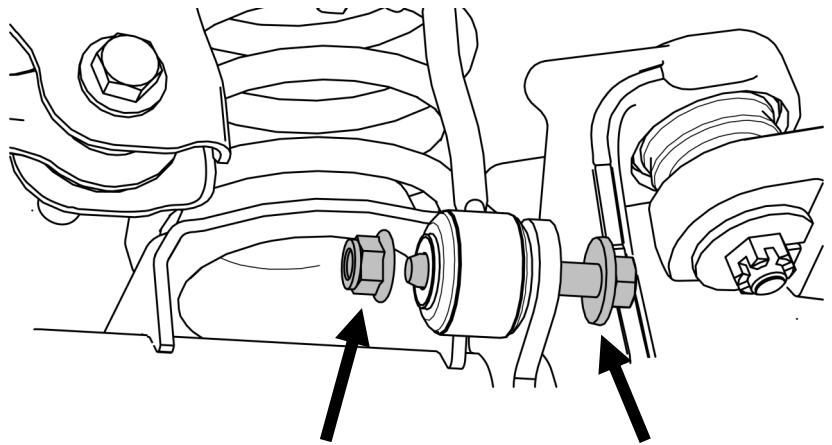
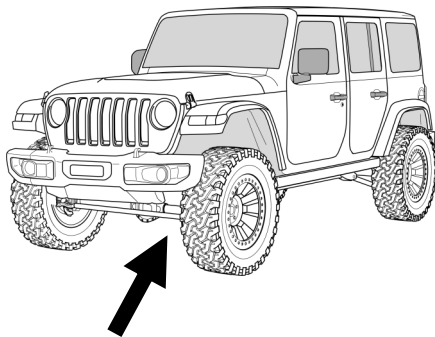

**REMOVE
NUT 18mm**

**REMOVE
BOLT 18mm**

5

REMOVE & DISCARD BRAKE LINE BRACKETS FROM LOWER CONTROL ARMS

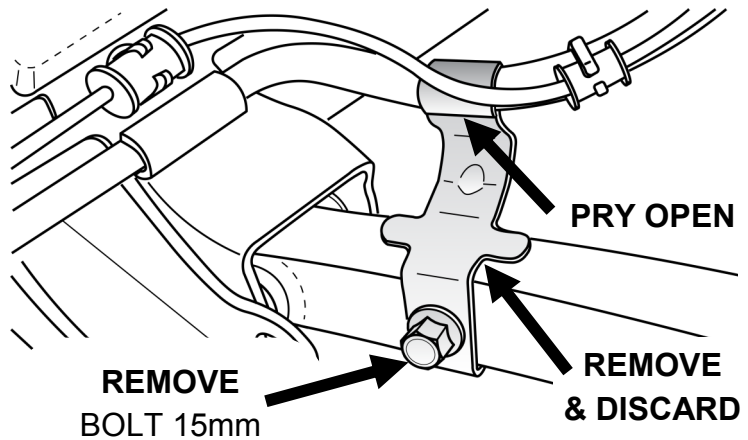
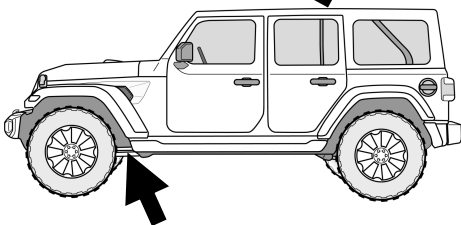
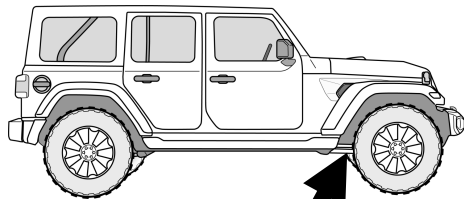

**REMOVE
BOLT 15mm**

PRY OPEN

**REMOVE
& DISCARD**

2x

6

DISCONNECT ACTUATORS AND VENT HOSE AT THE FRONT AXLE

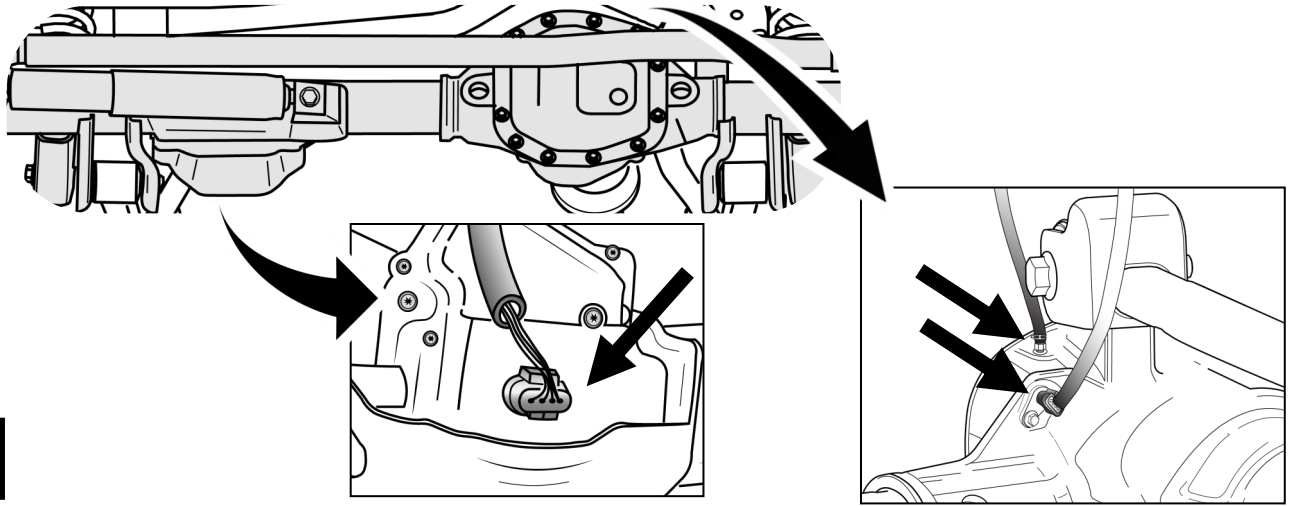

7

LOOSEN FRONT CONTROL ARM BOLTS

NOTE: DO NOT REMOVE THE CONTROL ARM BOLTS

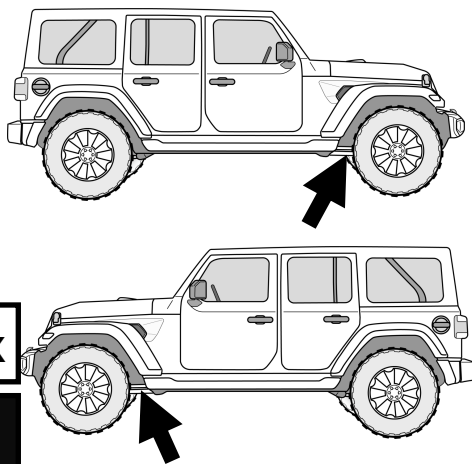

2x

8

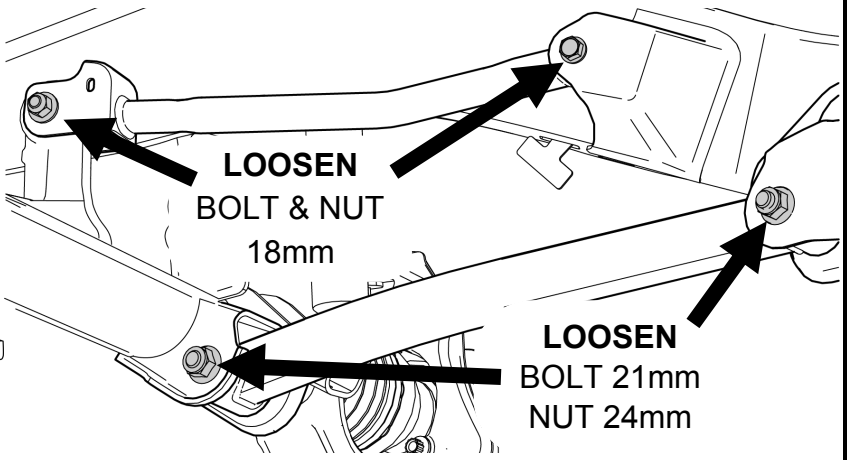

**LOOSEN
BOLT & NUT
18mm**

**LOOSEN
BOLT 21mm
NUT 24mm**

REMOVE SHOCKS AT THE AXLE

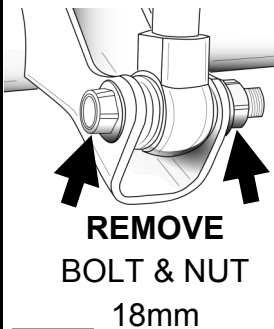

**REMOVE
BOLT & NUT
18mm**

***IF REPLACING*
SHOCKS
REMOVE UPPER
BOLT 18mm**

2x

9

LOWER AXLE & REMOVE SPRINGS

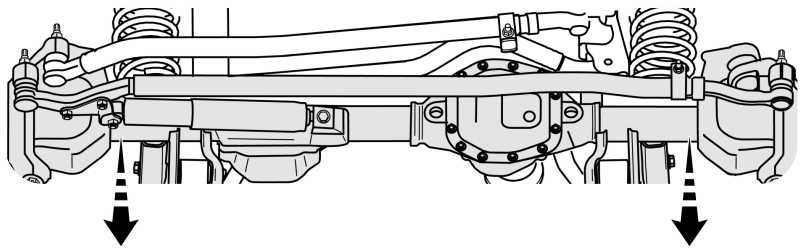

**NOTE: REMOVE ANY
PLASTIC RETAINERS
FROM WIRING OR
HOSES AS NEEDED.**

2x

10

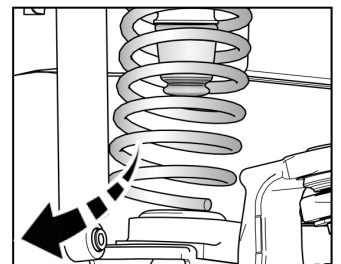

INSTALL SPRING SPACER & FACTORY SPRING ISOLATOR ONTO JOUNCE TUBES

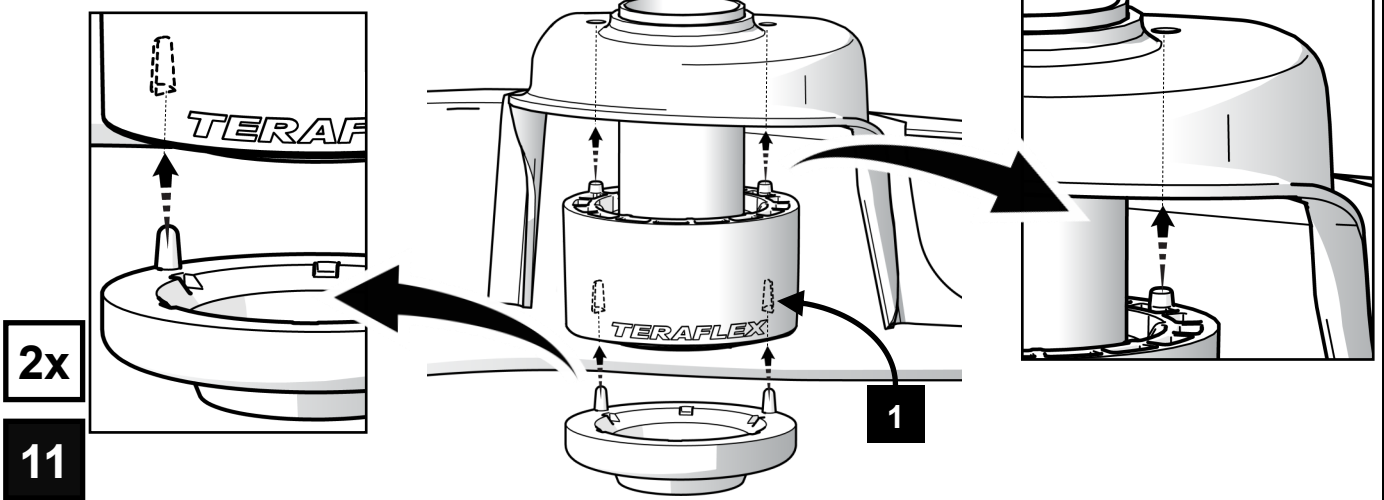

REINSTALL THE SPRINGS

NOTE: IF INSTALLING FALCON JOUNCE BUMPERS REFER TO INSTRUCTION #999308 BEFORE INSTALLING SPRINGS

2x

12

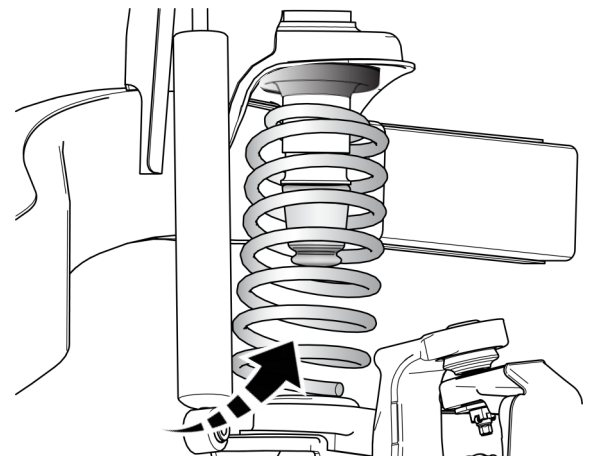

SEAT SPRINGS INTO LOWER SPRING ISOLATOR

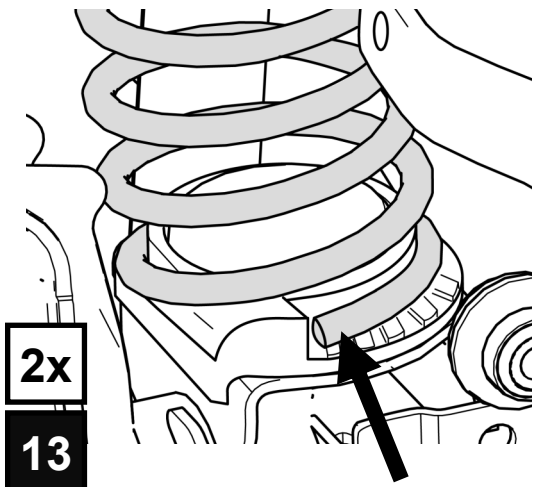

RAISE AXLE & INSTALL SHOCKS

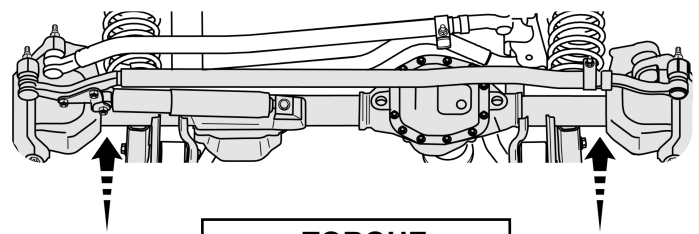

TORQUE
56 FT - LBS.
BOLT & NUT 18mm

RECONNECT ACTUATORS AND VENT HOSE TO FRONT AXLE

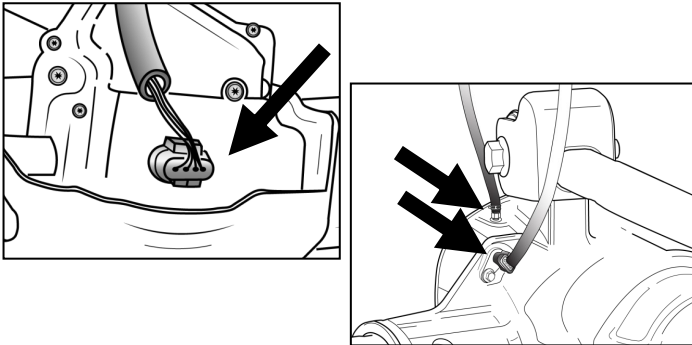

NOTE: DO NOT TIGHTEN THE CONTROL ARM BOLTS UNTIL THE JEEP IS ON THE GROUND

14

RECONNECT PLASTIC RETAINERS FROM WIRING OR HOSES AS NEEDED

NOTE: IF ONLY FRONT OF JEEP WAS LIFTED REINSTALL TIRES & WHEELS AND LOWER JEEP BACK TO THE GROUND BEFORE LIFTING THE REAR

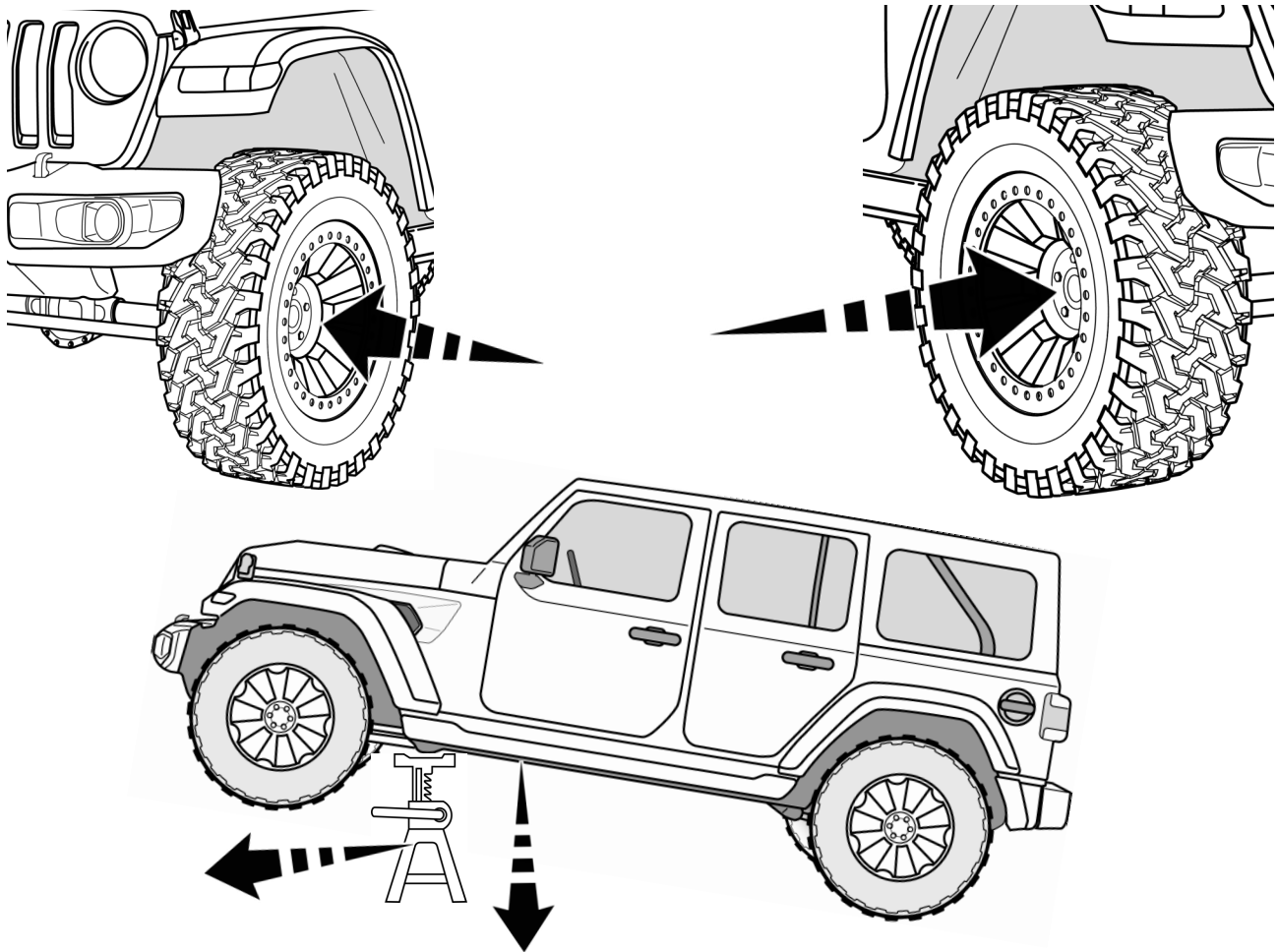

LIFT AND SUPPORT AT FRAME

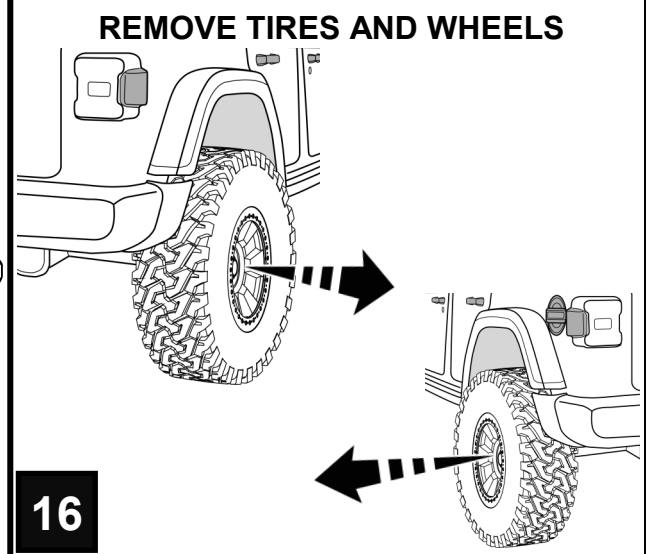
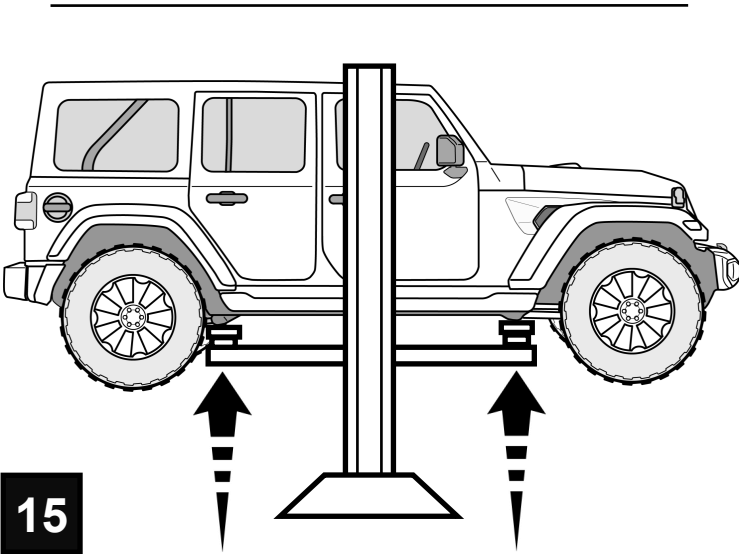
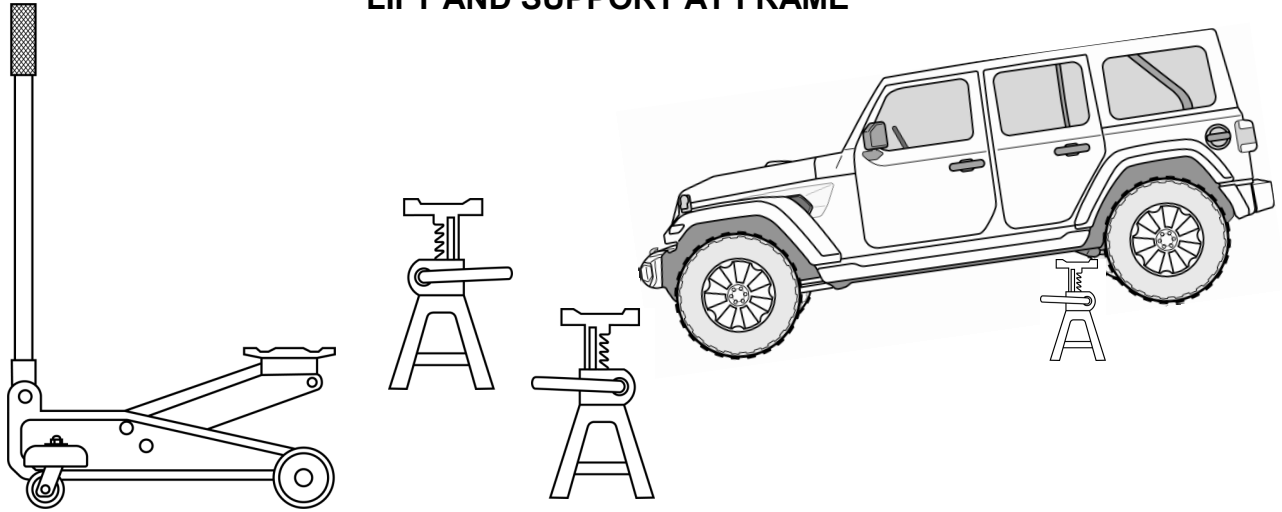

REMOVE TIRES AND WHEELS

SUPPORT REAR AXLE

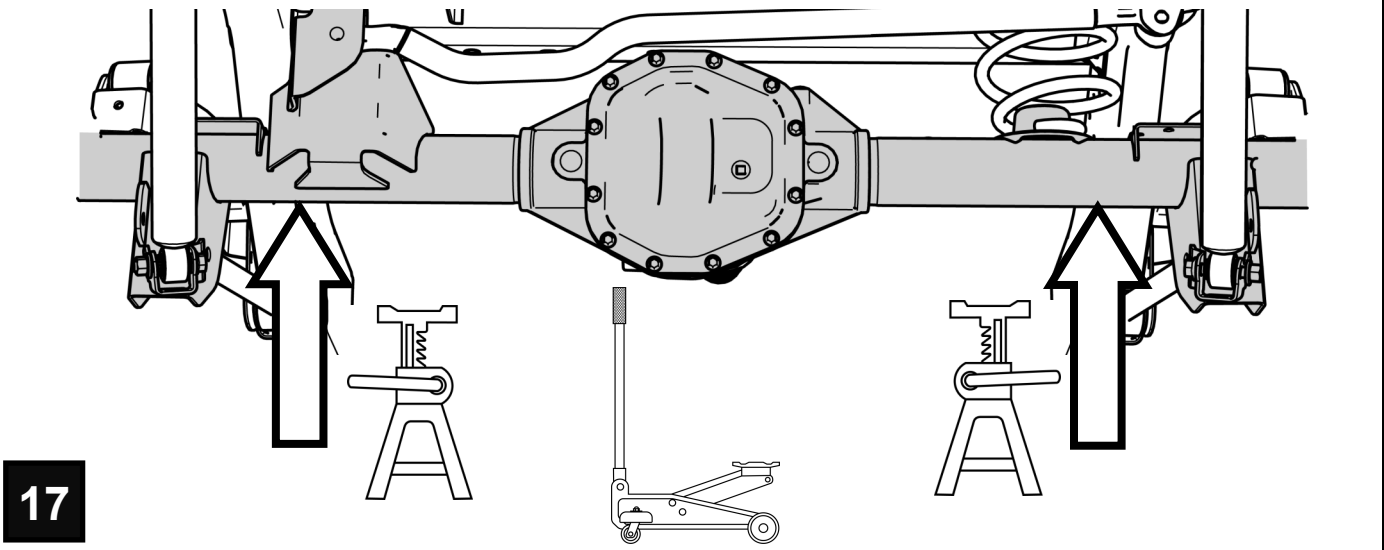

REMOVE E-BRAKE CABLE BRACKET AND DISCARD

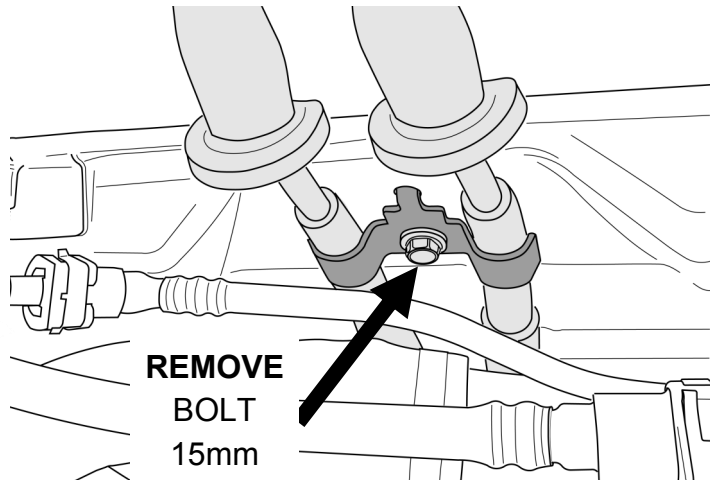
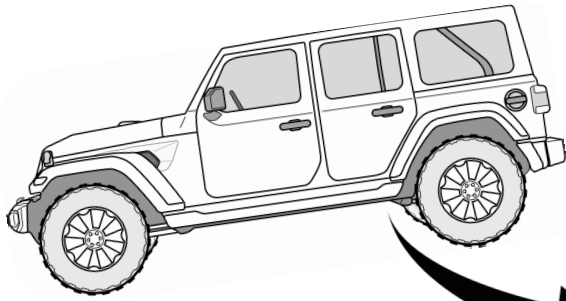

18

LOOSEN REAR CONTROL ARM BOLTS

DO NOT REMOVE THE CONTROL ARM BOLTS

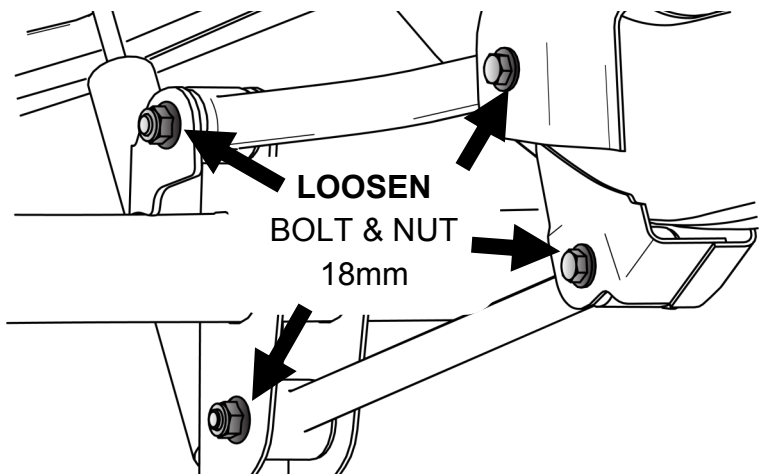
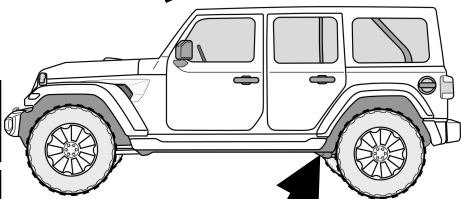
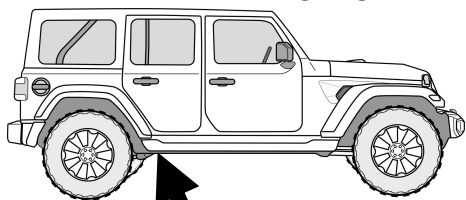

2x

19

REMOVE SWAY BAR LINKS AT THE AXLE

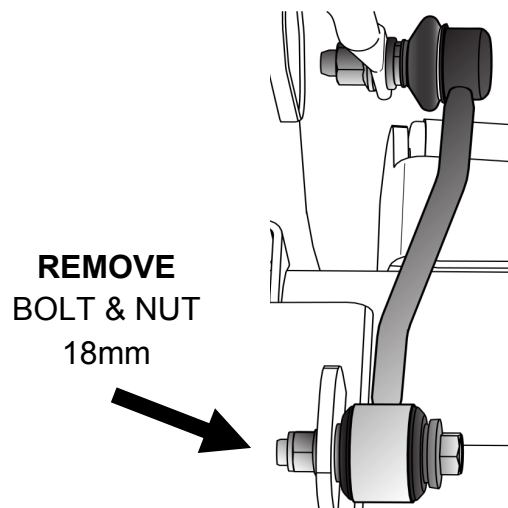
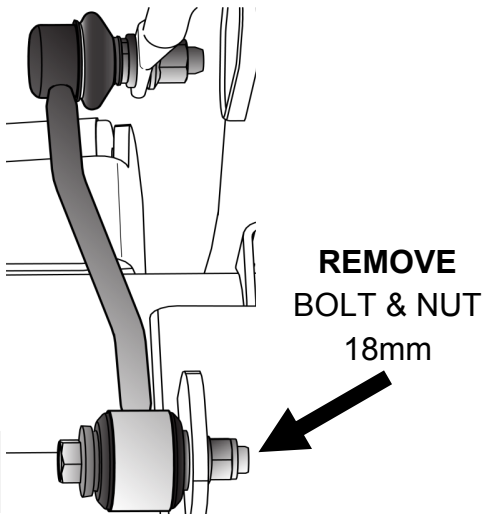

26

2x

REMOVE BRAKE LINE BRACKETS FROM AXLE

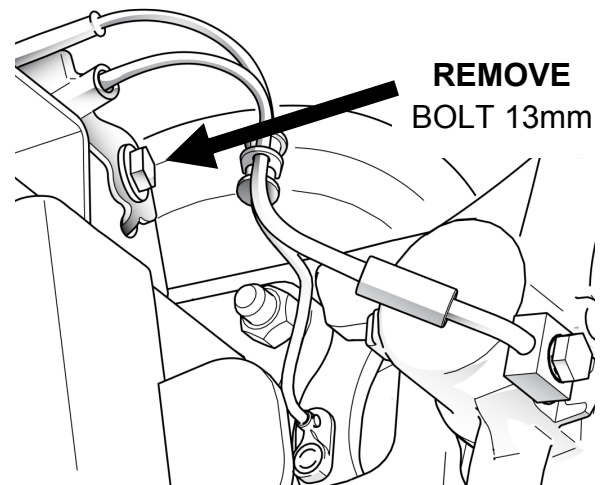
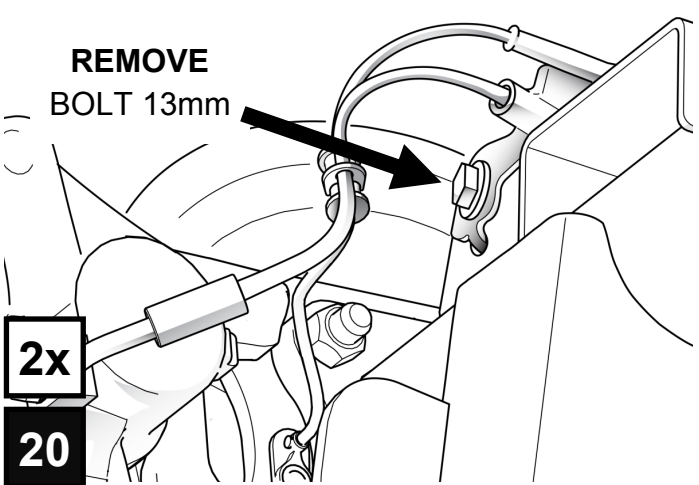

REMOVE THE TRACK BAR FROM THE AXLE

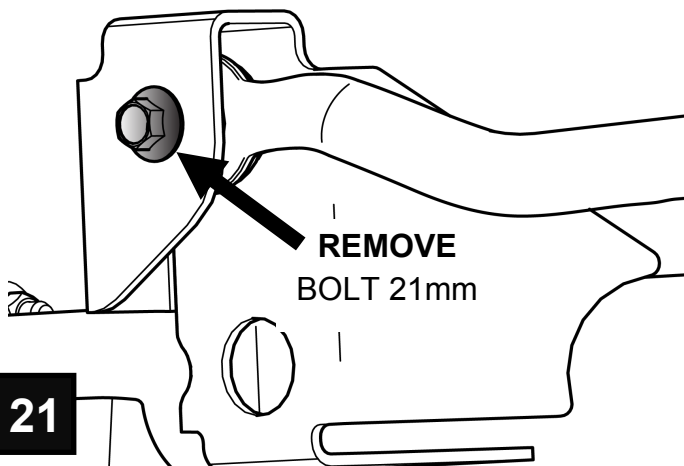

REMOVE SHOCKS AT THE AXLE

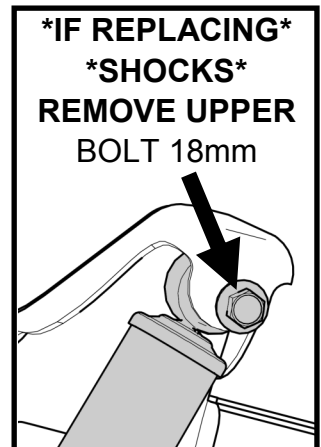
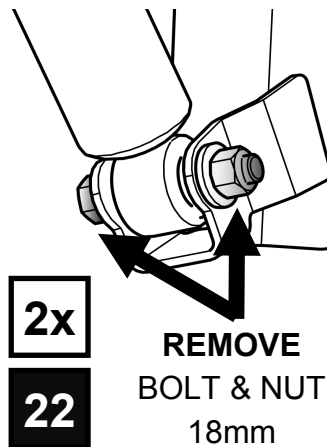

LOWER AXLE & REMOVE THE SPRINGS

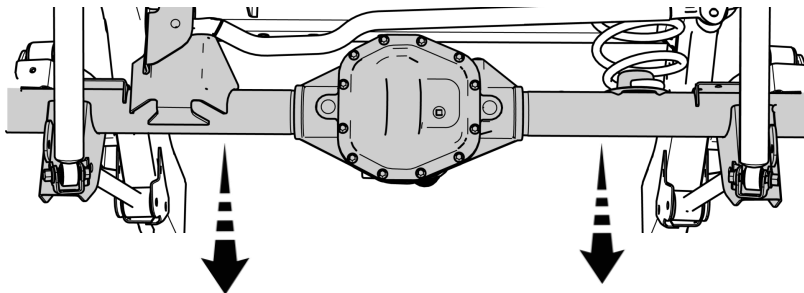

2x

23

NOTE: REMOVE ANY PLASTIC RETAINERS FROM WIRING OR HOSES AS NEEDED.

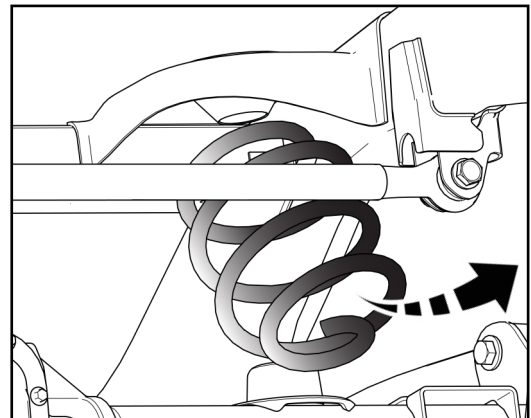

INSTALL REAR SPRING SPACER AND FACTORY SPRING ISOLATOR

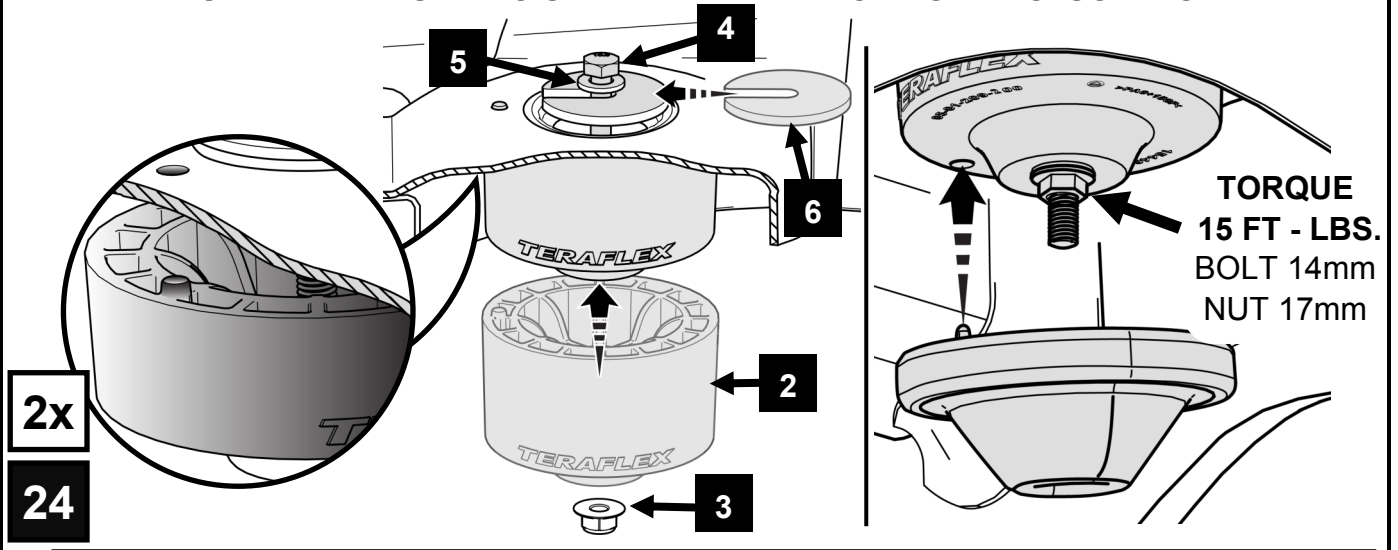

REINSTALL REAR SPRINGS

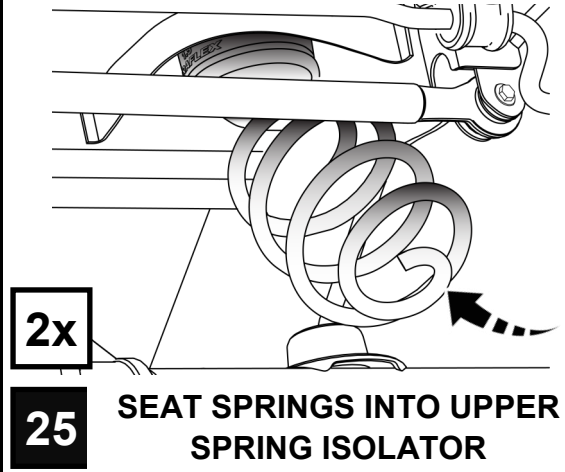

RAISE AXLE & INSTALL SHOCKS

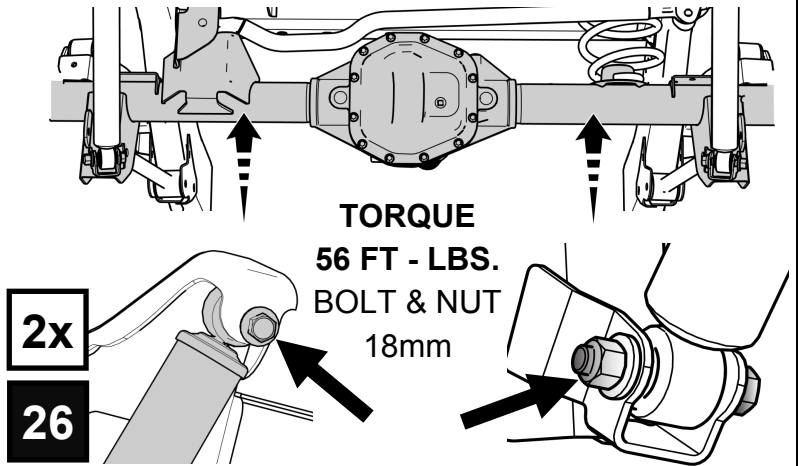

REINSTALL BRAKE LINE BRACKETS

RECONNECT PLASTIC RETAINERS FROM WIRING OR HOSES AS NEEDED

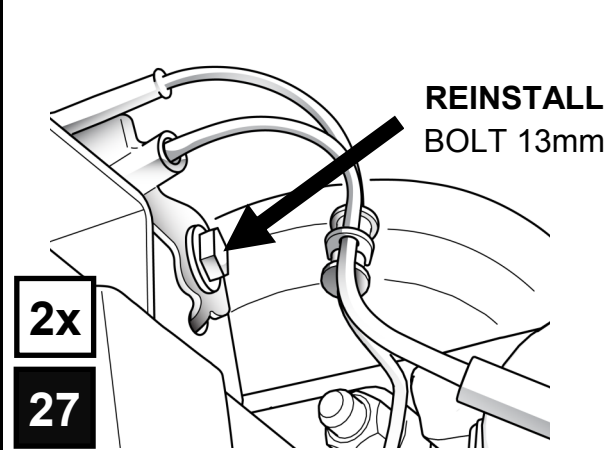

REINSTALL SWAY BAR LINKS TO AXLE

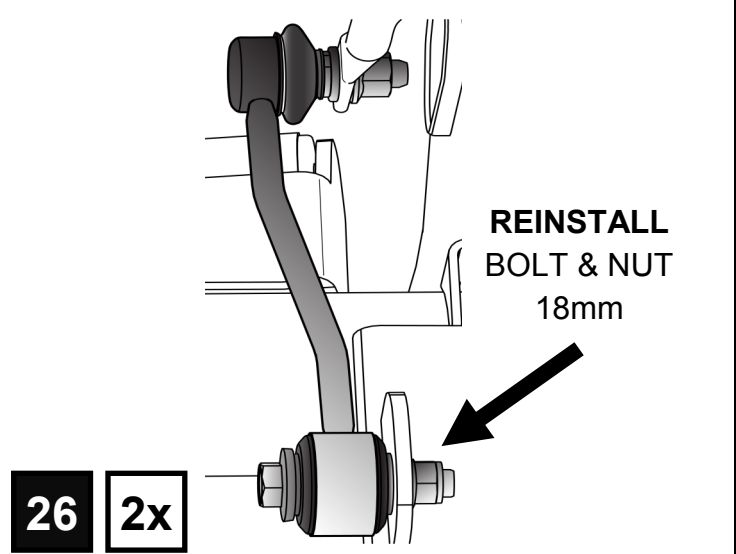

REINSTALL TIRES AND WHEELS AND LOWER JEEP TO GROUND

NOTE: DO NOT TIGHTEN THE CONTROL ARM BOLTS UNTIL THE JEEP IS ON THE GROUND

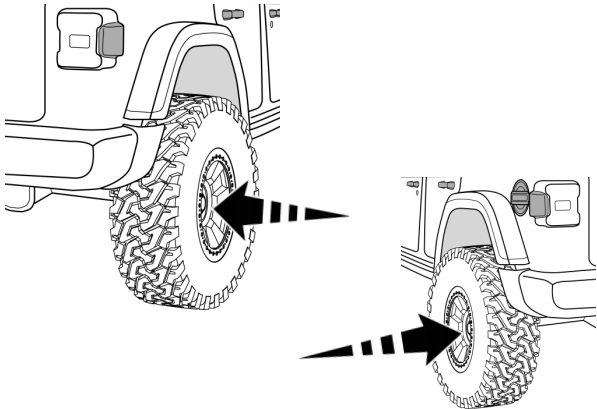

TORQUE TO FACTORY SPEC

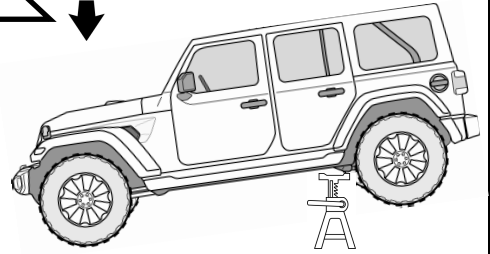
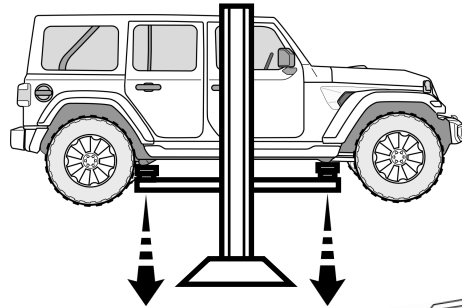

28

REINSTALL TRACK BARS AND TORQUE TO FACTORY SPECS

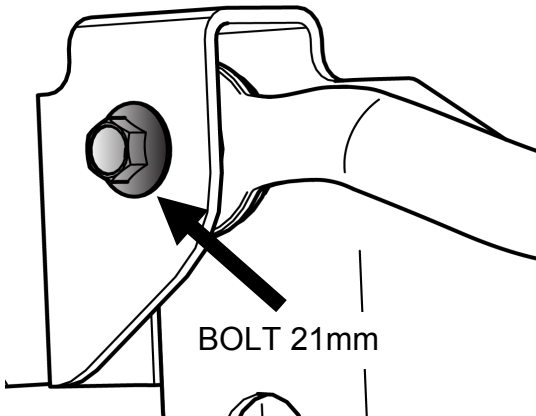

BOLT 21mm

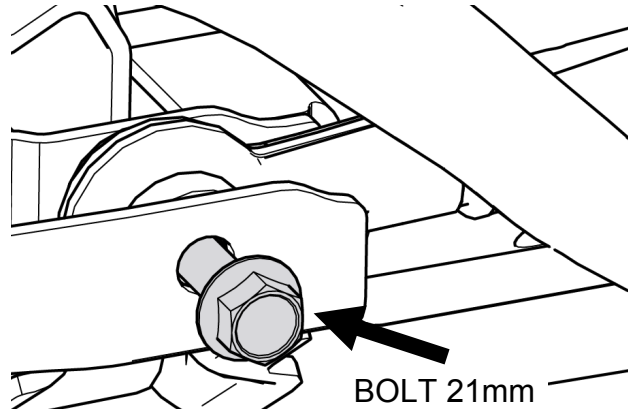

BOLT 21mm

29

TORQUE FRONT AND REAR CONTROL ARM BOLTS TO FACTORY SPECS

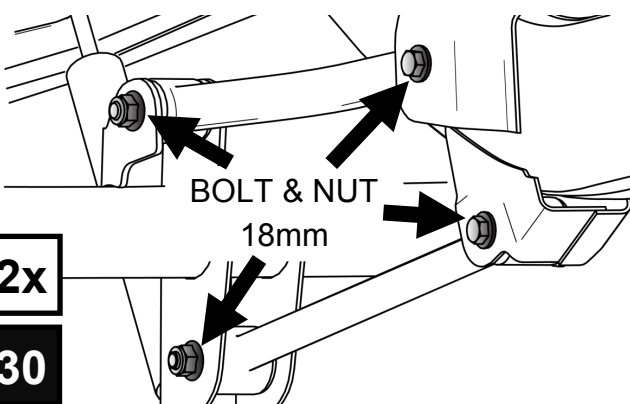

**BOLT & NUT
18mm**

2x

30

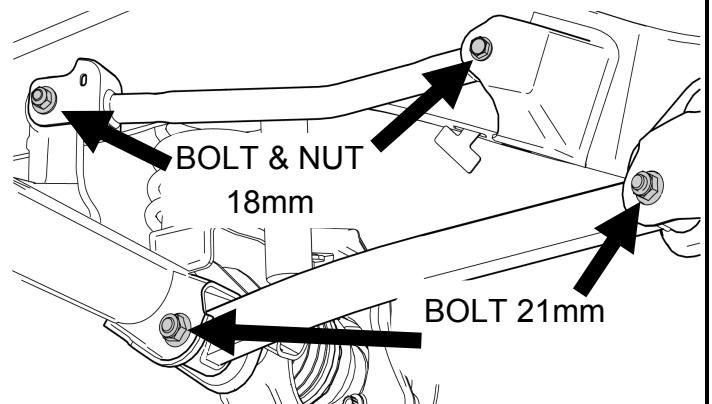

**BOLT & NUT
18mm**

BOLT 21mm

PRODUCT INFORMATION

MAINTENANCE INFORMATION:

It is the buyer's responsibility to have all suspension, drivetrain, steering, and other components checked for proper tightness and torque after the first 100 miles and every 3000 miles after that.

NOTICE TO INSTALLER:

The enclosed "Warning to Driver" sticker must be installed in the vehicle in driver's view. This sticker is to act as a constant safety reminder when operating the vehicle. It is your responsibility as the equipment installer to install the provided sticker and to forward the product instructions to the vehicle's owner for review. If a "Warning to Driver" sticker or product installation guide were not included in the kit, FREE replacement stickers and instructions are available by request. It is the installer's duty to ensure a safe and controllable vehicle after the modifications have been performed.

WARNING:

Neither the seller nor the manufacturer will be liable for any loss, damage, or injury directly or indirectly arising from the use of or inability to determine the use of these products. Before using, the user shall determine the suitability of the products for its intended use, and the user shall assume all responsibility and risk in connection therewith.

WARNING TO DRIVER:

This vehicle has been modified to enhance off road performance and has unique handling characteristics. Use in harsh environments can cause extreme stress on the components. Vehicle should be inspected after being off road to make sure that all the components are in working order and safe to travel on the highway. All fasteners should be checked so that they are at the correct torque specifications as the vibration and stresses from off roading may cause critical fasteners to work loose. Extra care should be taken to inspect the critical components, steering, and brake systems. During each oil change components such as arms, tie rod ends, etc should be greased and checked for excessive wear. Any worn components should be replaced. When returning to the pavement always set or restore tire air pressure to the factory recommendation and connect or engage any disabled sway bar mechanisms. Because of the higher center of gravity and larger tires, this vehicle handles and reacts differently than many passenger cars, both on and off road. You must drive it safely! Extreme care should be taken to prevent vehicle rollover or loss of control, which can result in serious injury or death. Avoid sudden sharp turns or abrupt maneuvers. Generally, braking performance and capabilities are decreased when significantly larger/heavier tires are used, especially when used in combination with transfer case low-range reduction kits. Take this into consideration while driving. Do not add, alter or fabricate any factory or aftermarket parts to increase vehicle height over the intended height of the TeraFlex product purchased. Mixing component brand is not recommended. TeraFlex Inc. will not be responsible for any altered product or any improper installation or use of our products. We will be happy to answer any questions concerning the design, function, and correct use of our products. It is ultimately the buyer's responsibility to have all bolts/nuts checked for tightness after the first 100 miles and then every 3000 miles. Wheel alignment, steering system, suspension and drive line systems must be inspected by a qualified professional mechanic at least every 3000 miles.

TERAFLEX PRODUCT WARRANTY:

TeraFlex Inc. warrants TeraFlex Suspension products to the original retail purchaser to be free of defects in material and workmanship for as long as the original purchaser owns the vehicle on which products were originally installed.

Failure to complete regular maintenance (grease every 3000 miles) on TeraFlex FlexArms will void this warranty. All other conditions of the standard TeraFlex product warranty apply.

All TeraLow products are covered by the TeraFlex two (2) year warranty to be free of defects in material and workmanship for two years from date purchased.

TeraFlex axles are covered by a 12-month warranty to be free of defects in materials and workmanship.

This warranty does not cover or include product finish, improperly installed or applied products, improperly maintained products, products or components used for racing or competition or damage due to abuse or neglect, products that fail due to the use of larger tire and wheel combinations.

All returns must be accompanied by an original invoice. It is the customer's responsibility to remove the product from the vehicle. Shipping charges are the responsibility of the customer. TeraFlex Inc. will pay the return freight if the product meets the terms of warranty.

This warranty is for the replacement or repair of defective TeraFlex products only and does not include freight charges, labor charges for removal of or installation of TeraFlex or related products or components, costs incurred due to down time of the vehicle, or lost profits due to vehicle down time.

A returned goods authorization number (RGA#) must accompany any returned products. For more information please contact a TeraFlex customer service representative.

COPYRIGHT

©Copyright 2014. All rights reserved, TeraFlex Inc. Reproduction of this catalog and/or any of its contents without written permission is strictly prohibited.

TeraFlex® is a registered trademark of TeraFlex Inc. All trade names and logos including but not limited to TeraFlex, FlexArms, RockGuard, Monster, and LCG are protected by law and duplication of trade names and/or logos are strictly prohibited.

TeraFlex Inc. reserves the right to update, discontinue, redesign, modify finish, part number or component build parts if deemed necessary without written notice.

TeraFlex Inc., and any associated dealers are not responsible for misprints or typographical errors that may have inadvertently been made within this instruction sheet.

Jeep® and the Jeep® grill are registered trademarks of Fiat Chrysler Automobiles N.V., and have no affiliation with TeraFlex Inc.

TERAFLEX, Inc.
5680 West Dannon Way
West Jordan, Utah 84081
Phone/801.713.3314
Fax/801.713.2313
www.teraflex.com