



JL,JK HIGH MODULUS BRAKE INSTALLATION

www.TERAFLEX.com

4403450- 5 Lug Rotors

4403480- 8 Lug Rotors

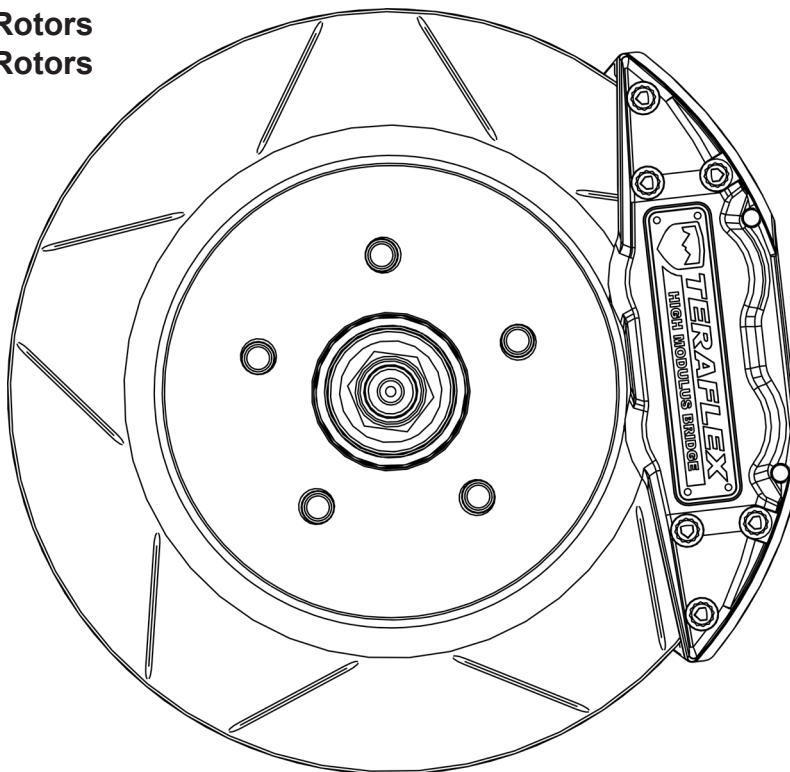

Important Notes:

Prior to beginning this install, or any installation, read the instructions thoroughly to familiarize yourself with the required steps. Evaluate if you are experienced and capable to personally perform these modifications. A factory service manual should be used in conjunction with these installation instructions.

This product will change the braking characteristics of your vehicle, exercise caution.

Refer to the parts list to ensure that all necessary components and hardware has been included. If any parts are missing please contact your local TeraFlex dealer for assistance.

IF INSTALLING ON A JK MODEL WE RECOMMEND USING THE "J8 BRAKE BOOSTER" (PART # P5160050). JK MODELS WITH A MANUAL TRANSMISSION WILL NEED AN ADDITIONAL CLUTCH RESERVOIR. WE RECOMEND PART # 92065790. IF INSTALLING ON A JL MODEL THE FACTORY BRAKE BOOSTER IS SUFFICIENT.

BEFORE INSTALLING BRAKES, VERIFY CALIPER CLEARANCE USING THE WHEEL FITMENT TEMPLATE AT THE BACK OF THESE INSTRUCTIONS.

Tools Needed:

- Metric Sockets and Open End Wrenches
- Torque Wrench
- Cut Off Wheel / Tin Snips
- Factory Service Manual
- General Mechanics Tools

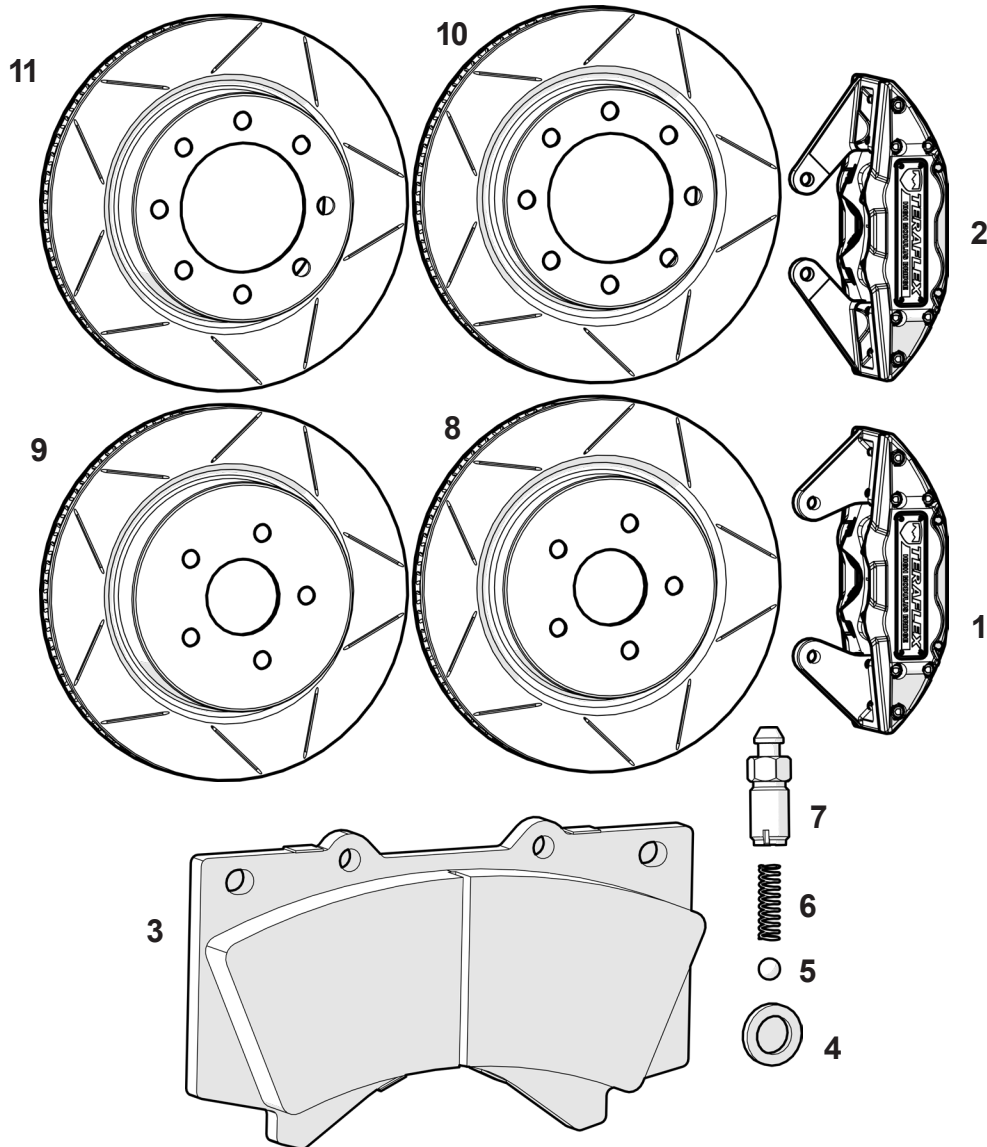

Item #	Part No.	Description	QTY
1	4403401	Front High Modulus Brake Caliper Kit Pair	1
2	4403402	Rear High Modulus Brake Caliper Kit Pair	1
3	13-1-03-001	Brake Pads Kit, Front or Rear, 5.65" Wide / High Friction	2
4	86291	3/8" Copper Banjo Bolt Washer	8
5	09-1-01-002	Check Valve, 5/16" Ball Bearing	4
6	09-3-01-001	Check Valve Spring	4
7	09-1-01-001	Check Valve, M10 X 1.0	4
	4403450	JL/JK Delta Brake Kit - Front & Rear - 5x5" Bolt Pattern	
8	4403455	JL / JK Front 14" Diameter 1.25" Thick 5 Bolt Pattern (Pair)	1
9	4403456	JL / JK Rear 14" Diameter 1.25" Thick 5 Bolt Pattern (Pair)	1
	4403480	JL/JK Delta Brake Kit - Front & Rear - 8x6.5" Bolt Pattern	
10	4403485	JL / JK Front 14" Diameter 1.25" Thick 8 Bolt Pattern (Pair)	1
11	4403486	JL / JK Rear 14" Diameter 1.25" Thick 8 Bolt Pattern (Pair)	1

FRONT INSTALLATION

LIFT AND SUPPORT AT FRAME

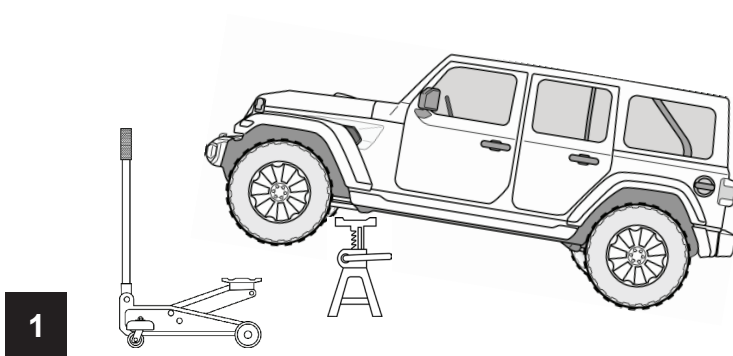

REMOVE FRONT TIRES

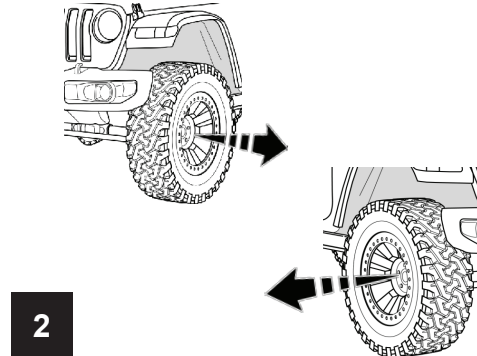

SUPPORT FRONT AXLE

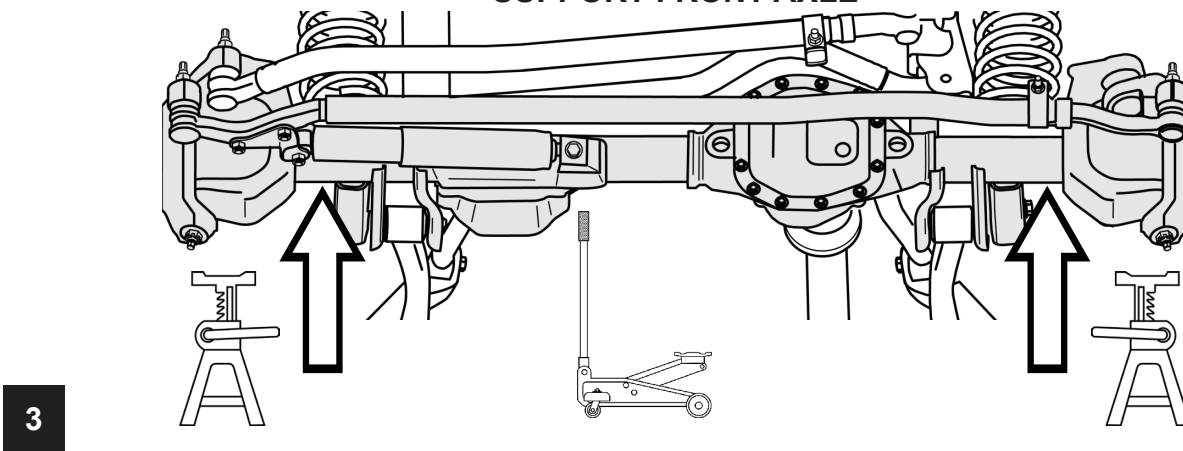

REMOVE AND DISCARD BRAKE LINE BRACKETS FROM LOWER CONTROL ARMS

NOTE: IF INSTALLING ON JEEP WITH 3"+ LIFT, YOU MAY NEED TO ALSO REMOVE THE BRAKE LINE ANCHOR FROM THE SPRING MOUNT AND USE TERAFLEX BRAKE LINE ANCHORS (PN # 1101255)

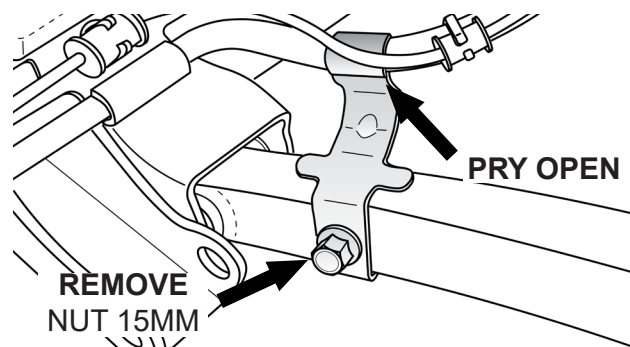
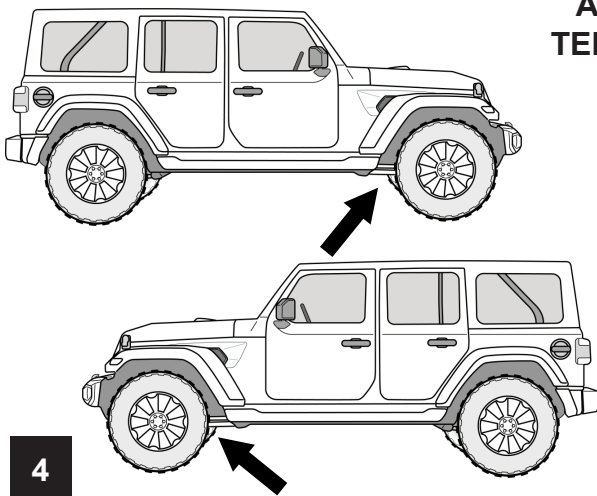

REMOVE THE FRONT CALIPERS AND ROTORS FROM THE FRONT AXLE

DO NOT HANG THE CALIPER BY THE BRAKE LINE

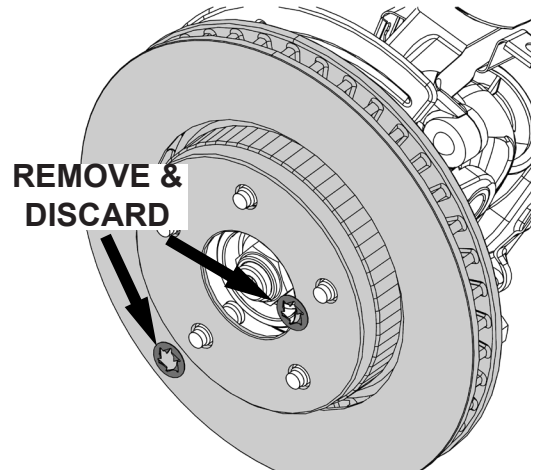
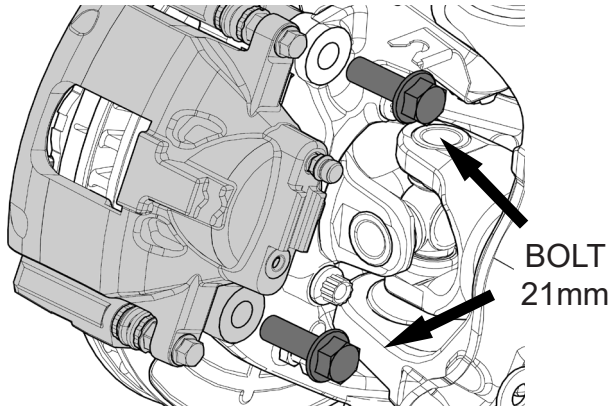

NOTE: JL MODELS USE T30 SCREWS IN PLACE OF ROTOR CLIPS

5

(JL MODEL ONLY) REMOVE THE BACKING PLATE TO ADJUST AND REINSTALL

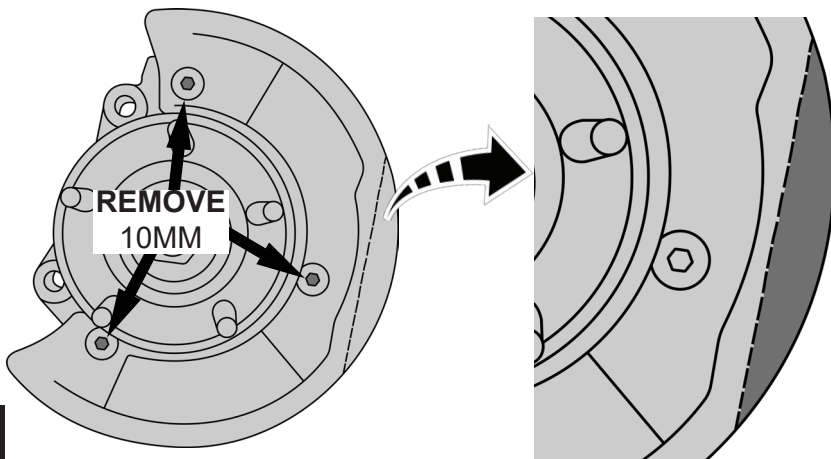

ONCE REMOVED FROM THE AXLE, GENTLY BEND THE FRONT EDGE INWARDS AT THE INDENTED LINE.

REINSTALL THE BACKING PLATE USING THE FACTORY HARDWARE.

TORQUE TO 10 FT LBS.

6

(JK MODEL ONLY) IF YOU HAVE UPGRADED STEERING LINKAGE YOU MAY NEED TO TRIM THE FRONT BACKING PLATE

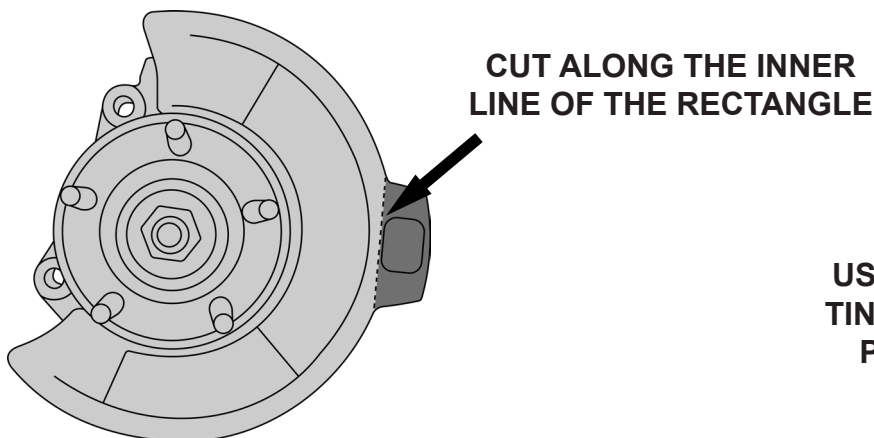

USE A CUT OFF WHEEL OR TIN SNIPS TO REMOVE THIS PART OF THE BACKING PLATE

7

INSTALL THE NEW TERAFLEX ROTOR

TEMPORARILY INSTALL A LUG NUT
TO HOLD ROTOR IN PLACE

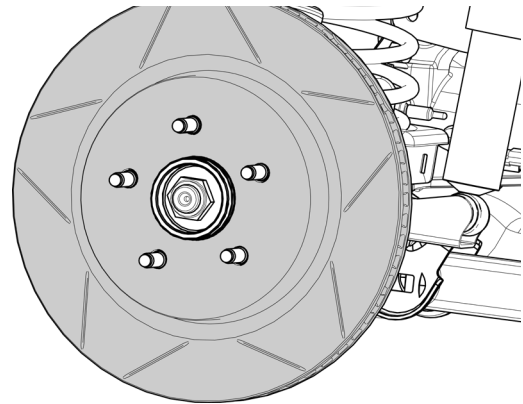

SPIN THE ROTOR TO MAKE SURE
THERE IS NO CONTACT WITH
THE BACKING PLATE

8

APPLY SYNTHETIC GREASE TO BACK AND SIDES OF THE PADS AS WELL AS
THE PAD PINS AND INSTALL THE PADS INTO THE CALIPERS

NOTE: MAKE SURE EACH CALIPER IS ASSEMBLED WITH THE OUTSIDE PAD CON-
TAINING A WEAR INDICATOR POINTING TOWARDS THE TOP OF THE JEEP

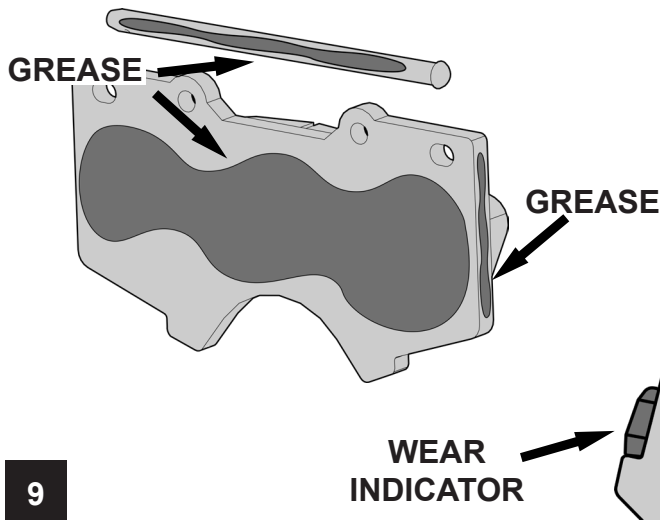

SLIDE THE PADS INTO POSITION AND
LOCK INTO PLACE WITH THE PAD PINS
AND SPRINGS.

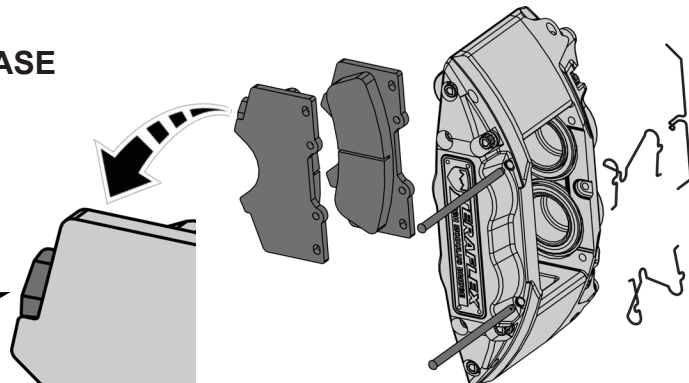

9

INSTALL THE SEPARATOR SPRINGS AND LOCK THE PAD PINS INTO POSITION

TUCK EACH END OF THE SEPARATOR
SPRINGS INTO THE HOLES ON THE PADS

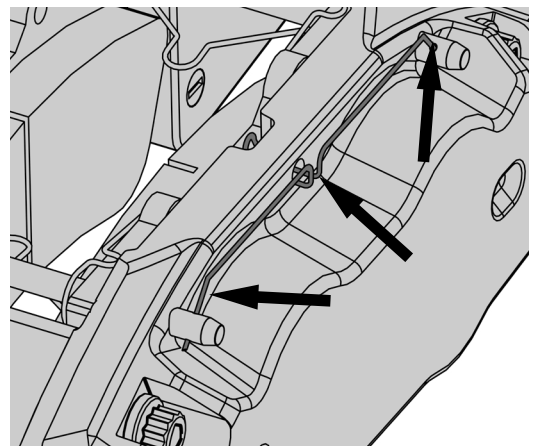
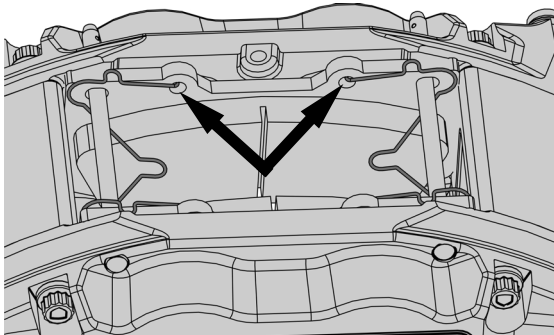

10

INSTALL THE TERAFLEX CALIPER ONTO THE KNUCKLE USING THE FACTORY BOLTS

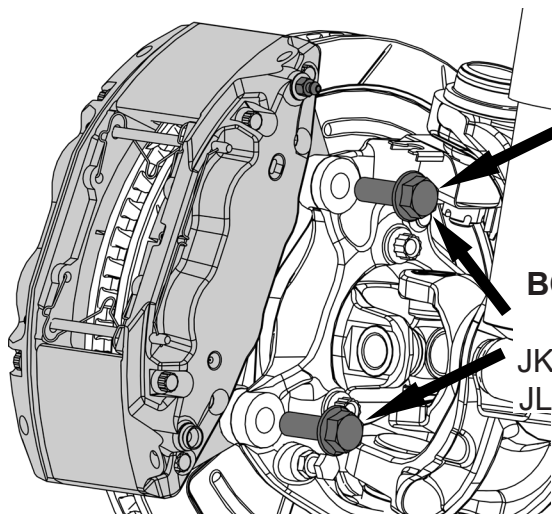

**USE BLUE
THREAD LOCK ON THE
FACTORY CALIPER
BOLTS**

**BOLTS 21mm
TORQUE:
JK: 100 FT-LBS
JL: 148 FT-LBS (FACTORY)**

11

REMOVE THE BRAKE LINE FROM THE STOCK CALIPER AND INSTALL IT ONTO THE TERAFLEX CALIPER FACING THE SAME DIRECTION AND POINTING SLIGHTLY DOWNWARDS WITH THE SUPPLIED CRUSH WASHERS

**BE PREPARED WITH BRAKE LINE
CLAMPS OR DRAIN PAN**

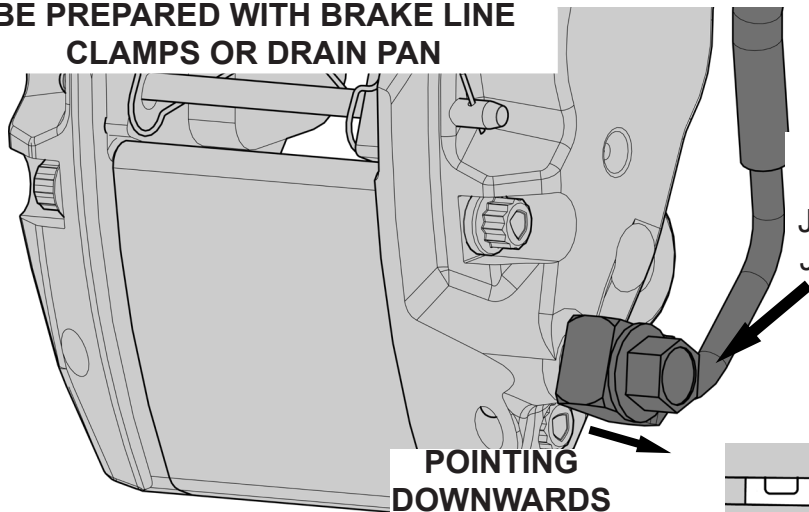

**BOLT 15mm
TORQUE:
JK: 25 FT-LBS
JL: 25 FT-LBS**

**POINTING
DOWNWARDS**

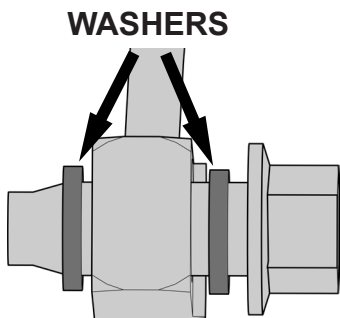

WASHERS

**NOTE: (JL SPORT ONLY)
INSTALL BRAKE LINES AS
SHOWN AND CAREFULLY
BEND THE LINE UPWARDS**

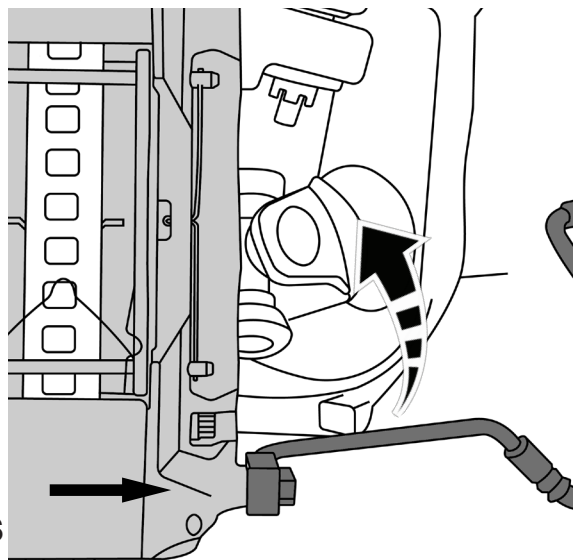

12

BEFORE INSTALLING THE BLEED VALVE ASSEMBLY (FINGER TIGHT)
WAIT FOR BRAKE FLUID TO SEEP FROM THE TOP HOLE

MAKE SURE BRAKE MASTER CYLINDER HAS FLUID

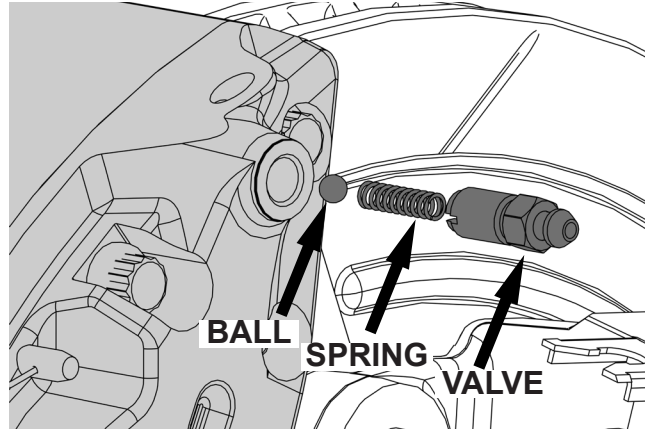

13

NOTE: IF ONLY FRONT OF JEEP WAS LIFTED, REINSTALL TIRES AND LOWER JEEP BACK TO THE GROUND BEFORE LIFTING THE REAR

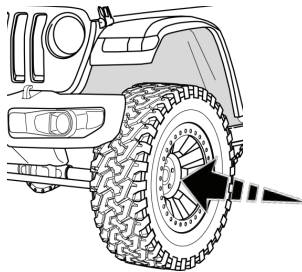

TORQUE:
JK: 100 FT-LBS
JL:130 FT-LBS

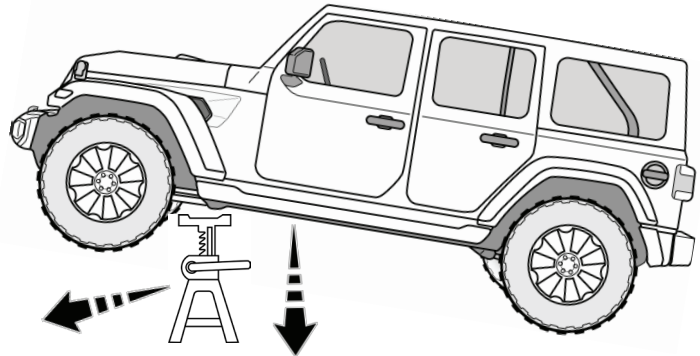
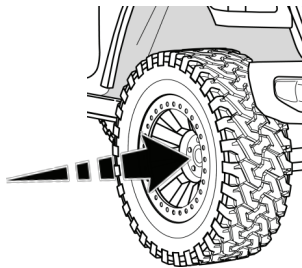

14

REAR INSTALL LIFT AND SUPPORT AT FRAME

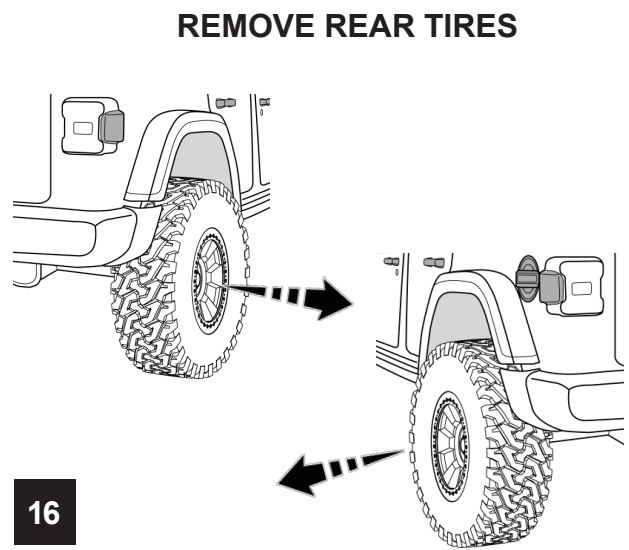
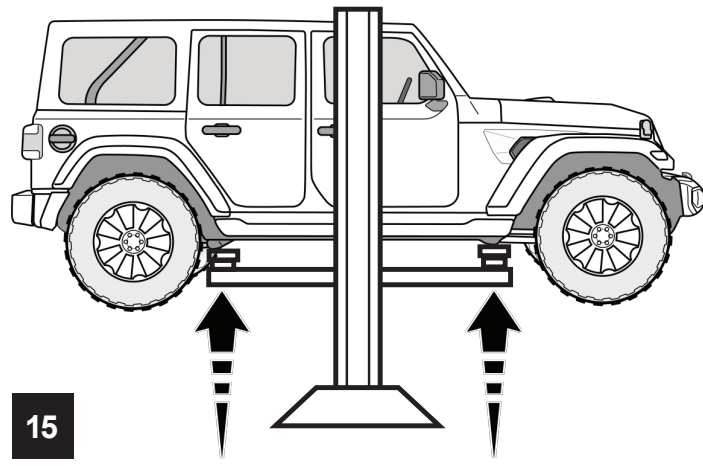
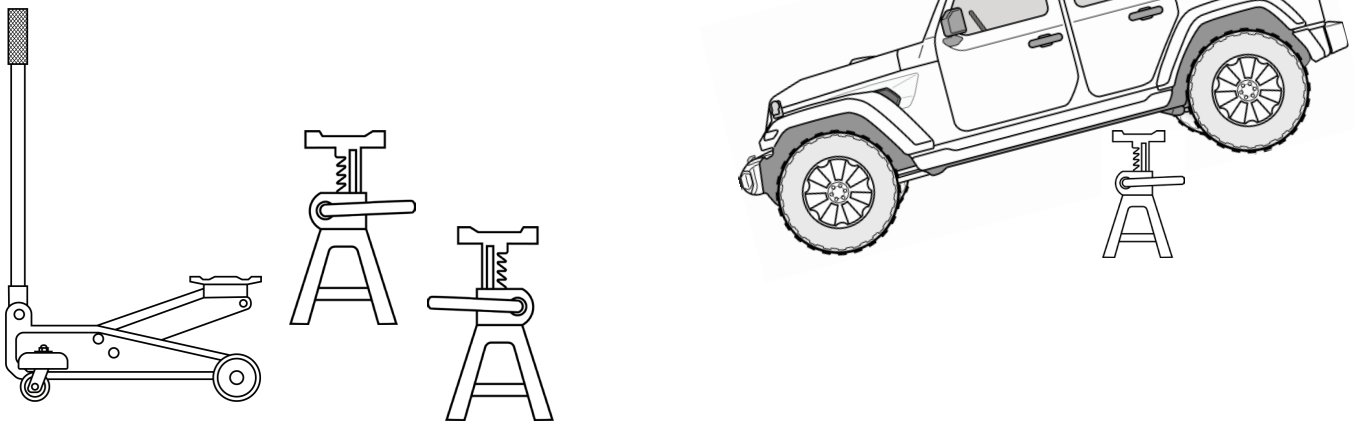

SUPPORT REAR AXLE

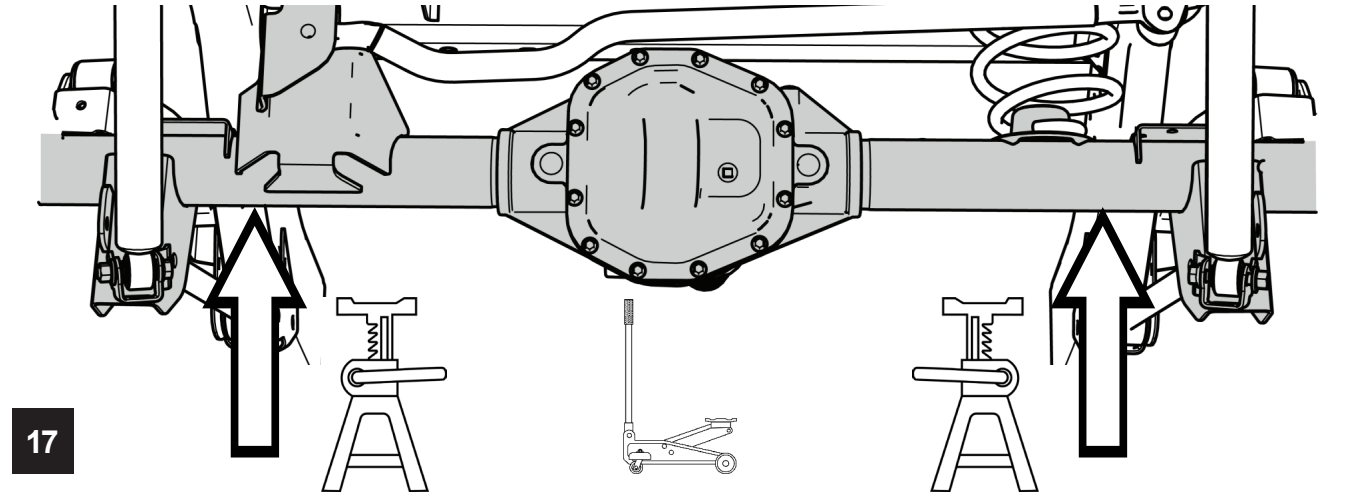

REMOVE THE REAR CALIPERS FROM THE AXLE

NOTE: (JL MODELS ONLY)

BEFORE REMOVING THE CALIPER FROM THE AXLE, CAREFULLY BEND THE BRAKE LINE AWAY FROM THE AXLE UNTIL IT IS SLIGHTLY BENT OUTWARDS

DO NOT HANG THE CALIPER FROM THE BRAKE LINE

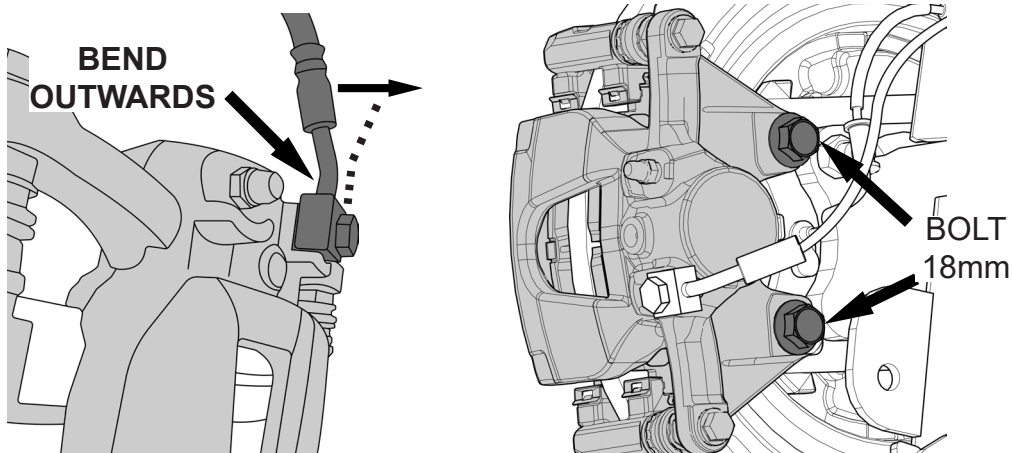

18

REMOVE THE FACTORY ROTORS

NOTE: JL MODELS USE T30 SCREWS TO RETAIN ROTORS. JK MODELS USE ROTOR CLIPS. REMOVE AND DISCARD.

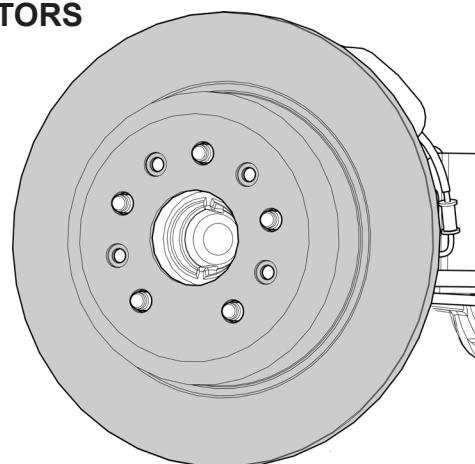

19

(JL MODELS ONLY) TRIM THE REAR BACKING PLATE

TEMPORARILY INSTALL THE DELTA CALIPERS ONTO THE AXLE AND MARK THE BACKING PLATE ALONG THE BRIDGE.

REMOVE THE CALIPER AND USE A CUT OFF WHEEL OR TIN SNIPS TO TRIM OFF THE REAR TIPS.

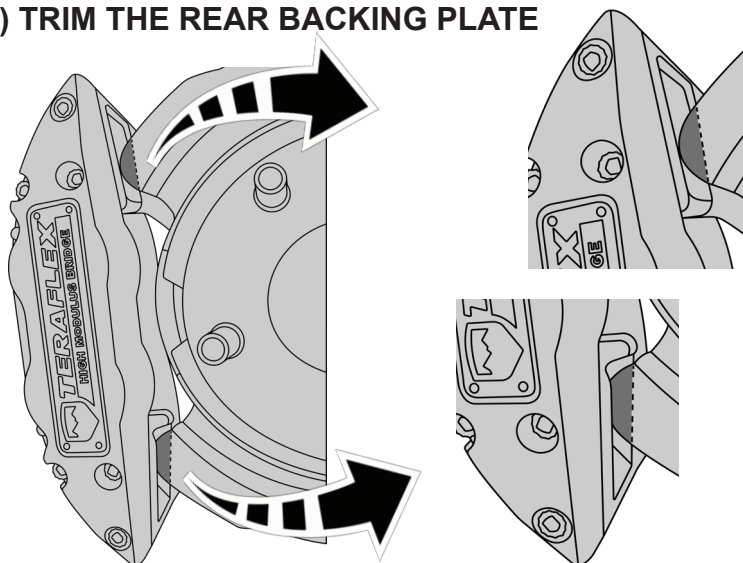

20

INSTALL THE NEW TERAFLEX ROTOR

TEMPORARILY INSTALL A LUG NUT TO HOLD ROTOR IN PLACE

SPIN THE ROTOR TO MAKE SURE THERE IS NO CONTACT WITH THE BACKING PLATE

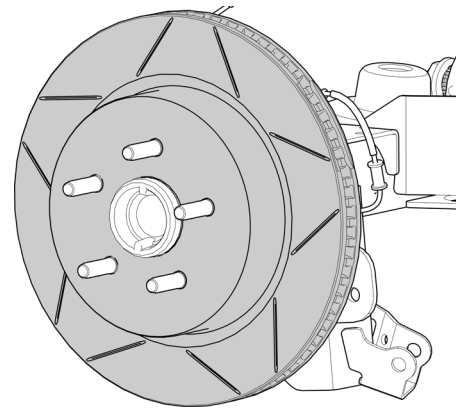

21

APPLY SYNTHETIC GREASE TO BACK AND SIDES OF THE PADS AS WELL AS THE PAD PINS AND INSTALL THE PADS INTO THE CALIPERS

NOTE: MAKE SURE EACH CALPER IS ASSEMBLED WITH THE OUTSIDE PAD CONTAINING A WEAR INDICATOR POINTING TOWARDS THE TOP OF THE JEEP

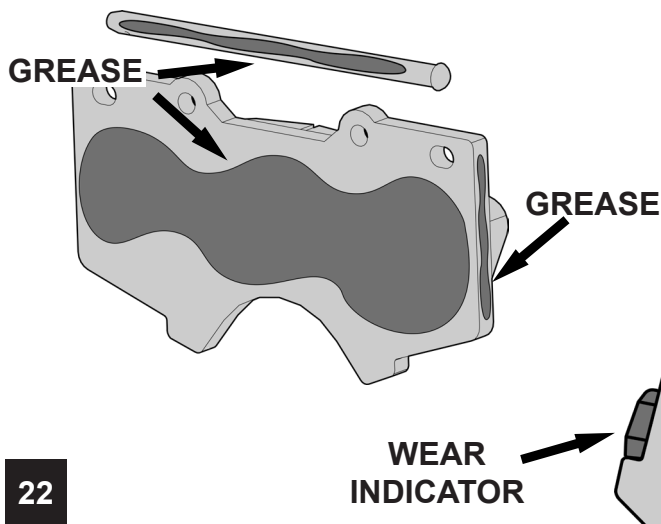

SLIDE THE PADS INTO POSITION AND LOCK INTO PLACE WITH THE PAD PINS AND SPRINGS.

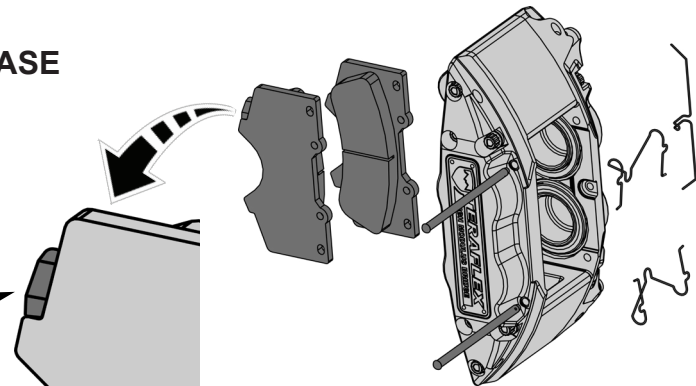

22

INSTALL THE SEPARATOR SPRINGS AND LOCK THE PAD PINS INTO POSITION

TUCK EACH END OF THE SEPARATOR SPRINGS INTO THE HOLES ON THE PADS

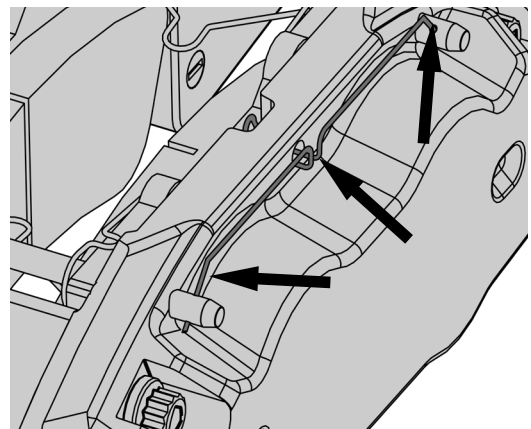
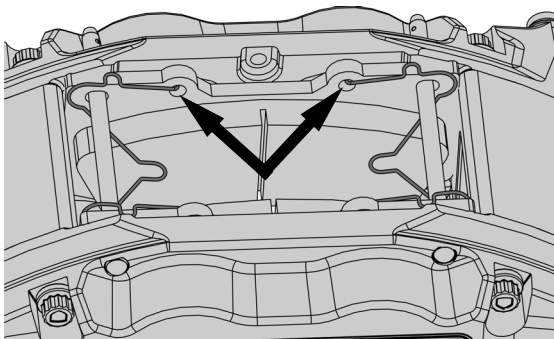

23

INSTALL THE TERAFLEX CALIPER ONTO THE AXLE USING THE FACTORY BOLTS

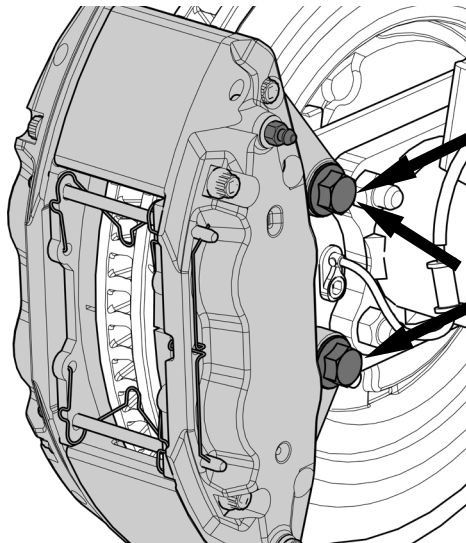

**USE BLUE
THREAD LOCK ON THE
FACTORY CALIPER
BOLTS**

**BOLTS 18mm
TORQUE:
JK: 77 FT-LBS
JL: 74 FT-LBS (FACTORY)**

24

REMOVE THE BRAKE LINE FROM THE STOCK CALIPER AND INSTALL IT ONTO THE TERAFLEX CALIPER WITH THE SUPPLIED CRUSH WASHERS

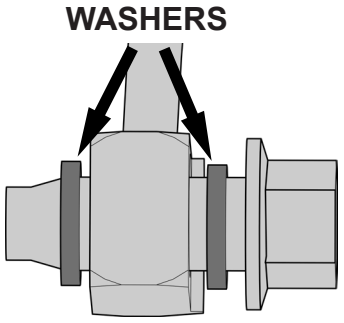
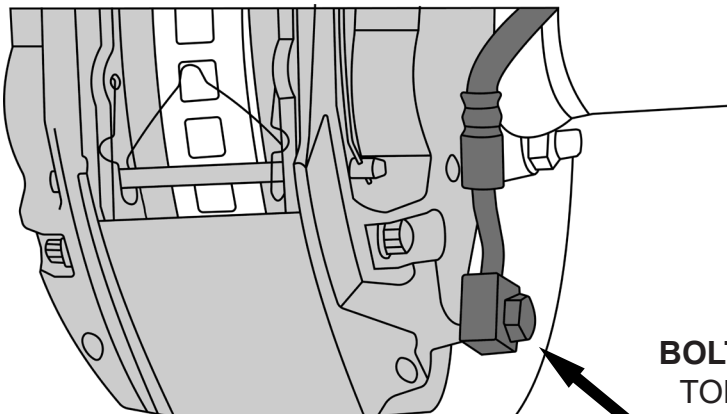

WASHERS

**BOLT 15mm
TORQUE:
JK: 25 FT-LBS
JL: 25 FT-LBS**

25

**BE PREPARED WITH BRAKE LINE
CLAMPS OR DRAIN PAN**

***BEFORE* INSTALLING THE
BLEED VALVE ASSEMBLY (FINGER
TIGHT)
WAIT FOR BRAKE FLUID TO SEEP
FROM THE TOP HOLE**

**MAKE SURE BRAKE MASTER
CYLINDER HAS FLUID**

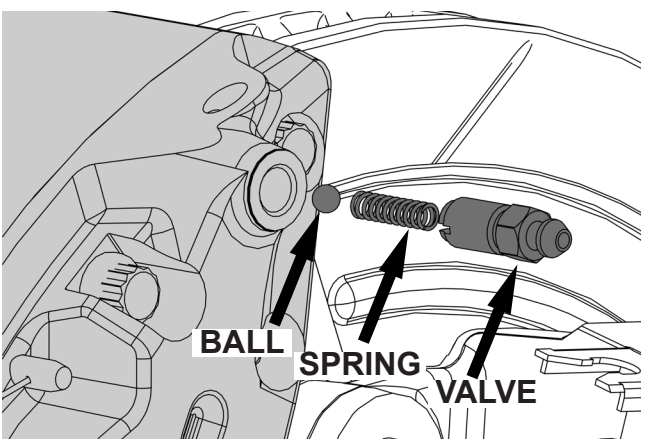

**BALL
SPRING
VALVE**

26

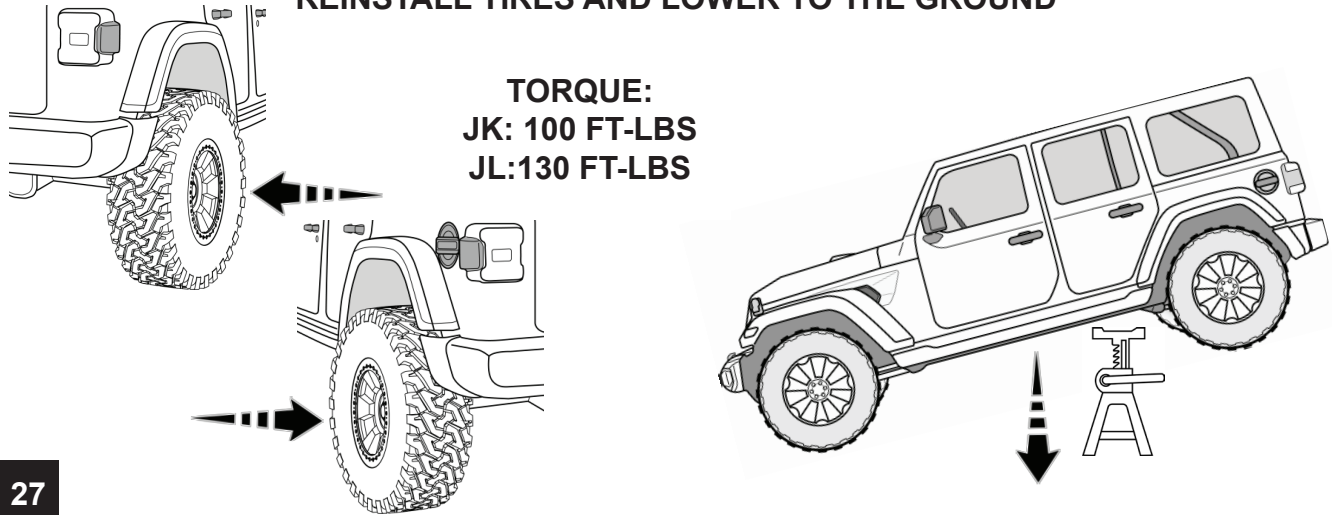
REINSTALL TIRES AND LOWER TO THE GROUND

27

BLEED THE BRAKE SYSTEM

- 1 FILL BRAKE RESERVOIR WITH APPROVED BRAKE FLUID**
- 2 UNSCREW THE PASSENGER REAR CALIPER BLEED VALVE 2 TURNS AND SLOWLY PRESS THE BRAKE PEDAL TO THE FLOOR TWICE**
- 3 RETIGHTEN THE BLEED VALVE AND TORQUE TO 25 FT LBS**
- 4 REPEAT THIS PROCESS NEXT FOR THE REAR DRIVER, FRONT PASSENGER, AND FINISH WITH THE FRONT DRIVER**
- 5 TOP OFF THE THE BRAKE FLUID RESERVOIR**
- 6 START THE JEEP AND VERIFY THE BRAKE PEDAL HAS FIRM PRESSURE**

(NOTE: AFTER CAUTIOUSLY TAKING THE JEEP FOR A DRIVE IT MAY BE NECESSARY TO REPEAT STEPS 2-4 TO PURGE ALL THE AIR FROM THE SYSTEM)

(NOTE: JEEP ABS SYSTEM CAN ALSO BE BLED USING A COMPUTER SCANNER IF AVAILABLE)

TERAFLEX

PRODUCT INFORMATION

MAINTENANCE INFORMATION:

It is the buyer's responsibility to have all suspension, drivetrain, steering, and other components checked for proper tightness and torque after the first 100 miles and every 3000 miles after that.

NOTICE TO INSTALLER:

The enclosed "Warning to Driver" sticker must be installed in the vehicle in driver's view. This sticker is to act as a constant safety reminder when operating the vehicle. It is your responsibility as the equipment installer to install the provided sticker and to forward the product instructions to the vehicle's owner for review. If a "Warning to Driver" sticker or product installation guide were not included in the kit, FREE replacement stickers and instructions are available by request. It is the installer's duty to ensure a safe and controllable vehicle after the modifications have been performed.

WARNING:

Neither the seller nor the manufacturer will be liable for any loss, damage, or injury directly or indirectly arising from the use of or inability to determine the use of these products. Before using, the user shall determine the suitability of the products for its intended use, and the user shall assume all responsibility and risk in connection therewith.

WARNING TO DRIVER:

This vehicle has been modified to enhance off road performance and has unique handling characteristics. Use in harsh environments can cause extreme stress on the components. Vehicle should be inspected after being off road to make sure that all the components are in working order and safe to travel on the highway. All fasteners should be checked so that they are at the correct torque specifications as the vibration and stresses from off roading may cause critical fasteners to work loose. Extra care should be taken to inspect the critical components, steering, and brake systems. During each oil change components such as arms, tie rod ends, etc should be greased and checked for excessive wear. Any worn components should be replaced. When returning to the pavement always set or restore tire air pressure to the factory recommendation and connect or engage any disabled sway bar mechanisms. Because of the higher center of gravity and larger tires, this vehicle handles and reacts differently than many passenger cars, both on and off road. You must drive it safely! Extreme care should be taken to prevent vehicle rollover or loss of control, which can result in serious injury or death. Avoid sudden sharp turns or abrupt maneuvers. Generally, braking performance and capabilities are decreased when significantly larger/heavier tires are used, especially when used in combination with transfer case low-range reduction kits. Take this into consideration while driving. Do not add, alter or fabricate any factory or aftermarket parts to increase vehicle height over the intended height of the TeraFlex product purchased. Mixing component brand is not recommended. TeraFlex Inc. will not be responsible for any altered product or any improper installation or use of our products. We will be happy to answer any questions concerning the design, function, and correct use of our products. It is ultimately the buyer's responsibility to have all bolts/nuts checked for tightness after the first 100 miles and then every 3000 miles. Wheel alignment, steering system, suspension and drive line systems must be inspected by a qualified professional mechanic at least every 3000 miles.

TERAFLEX PRODUCT WARRANTY:

TeraFlex Inc. warrants TeraFlex Suspension products to the original retail purchaser to be free of defects in material and workmanship for as long as the original purchaser owns the vehicle on which products were originally installed.

Failure to complete regular maintenance (grease every 3000 miles) on TeraFlex FlexArms will void this warranty. All other conditions of the standard TeraFlex product warranty apply.

All TeraLow products are covered by the TeraFlex two (2) year warranty to be free of defects in material and workmanship for two years from date purchased.

TeraFlex axles are covered by a 12-month warranty to be free of defects in materials and workmanship.

This warranty does not cover or include product finish, improperly installed or applied products, improperly maintained products, products or components used for racing or competition or damage due to abuse or neglect, products that fail due to the use of larger tire and wheel combinations.

All returns must be accompanied by an original invoice. It is the customer's responsibility to remove the product from the vehicle. Shipping charges are the responsibility of the customer. TeraFlex Inc. will pay the return freight if the product meets the terms of warranty.

This warranty is for the replacement or repair of defective TeraFlex products only and does not include freight charges, labor charges for removal of or installation of TeraFlex or related products or components, costs incurred due to down time of the vehicle, or lost profits due to vehicle down time.

A returned goods authorization number (RGA#) must accompany any returned products. For more information please contact a TeraFlex customer service representative.

COPYRIGHT

©Copyright 2014. All rights reserved, TeraFlex Inc. Reproduction of this catalog and/or any of its contents without written permission is strictly prohibited.

TeraFlex® is a registered trademark of TeraFlex Inc. All trade names and logos including but not limited to TeraFlex, FlexArms, RockGuard, Monster, and LCG are protected by law and duplication of trade names and/or logos are strictly prohibited.

TeraFlex Inc. reserves the right to update, discontinue, redesign, modify finish, part number or component build parts if deemed necessary without written notice. TeraFlex Inc., and any associated dealers are not responsible for misprints or typographical errors that may have inadvertently been made within this instruction sheet.

Jeep® and the Jeep® grill are registered trademarks of Fiat Chrysler Automobiles N.V., and have no affiliation with TeraFlex Inc.

TERAFLEX, Inc.
5680 West Dannon Way
West Jordan, UT. 84081
Phone/801.713.3314
Fax/801.713.2313
www.teraflex.com